

# Super Mario Bros. 3 FAQ/Walkthrough

by Beautiful Affair

Updated to v1.1 on Jan 1, 2006

```
&!!!! @@@@ @!!!!@ @!!!!!!@
!!!!!!% !!!! @@@@ @!!!!!!@ @@@!! @!!!!!!@ &!!!!!!!!!!!!!!!!!!#
%!!!!%!!@ !!!! @!!! @!!!!!!!!!!&#%!!!!!! @!!!!%!!!!@ &!!!!!!!!!!!!!!!!!!!!
#!!!!@ @@ !!!! @!!! @!!!@!!!&!!!!!!% @!!!! @!!!! @!!!!!!!!!!!!!!!!!!!!!!
@!!!!!!@ !!!! @!!! @!!!@ &!!&!!!!@ @!!!!##!!!! @!!!!!!!!!!!!!!!!!!!!!!
&!!!!!!& !!!! @!!! @!!!@ &!!&!!!!@ @!!!! @!!!! @!!!!!!!!!!!!!!!!!!!!!!
@!!!!!!@ !!!! @!!! @!!!@ !!&&!!!!!! @!!!!!!!!!!@ !!!!!!!!!!!%!!!!!!!!!
&!!!!!!@ !!!!!@!!!! @!!!!!!!!!!&!!!!!!@ #@!!!!!!!!!!# !!!!!!!!!!! !!!!!!!!!!!
@&!!!!!!# !!!!!!!!!!! @!!!!!!!!!!&#&!!!! # @!!!!!!!!!!@ !!!!!!!!!!! !!!!!!!!!!!
#!!!!!!& !!!!!!!!!!! @!!!!&&#&@!!!!&&!!!!@!!!!@!!!!&@ %!!!!!!!!!!
!!!!!!!!!! %!!!!!!!!!!@ @!!!!@ @&!!!!!!!!!!%@!!!!#@!!!! !!!!!!!!!!!
@!!!!%@ @!!!!@ @!!!!@ @!!!!!!!!!!%@ @!!!!!!# !!!!! @!!!!!!!!!!
!&@ # @@@@ @@@@## ##@ @ % !!!!!!!!!!!
& @@@@ @ @!!!!!!% @% @ @!!!!!!!!!!@ !!!!!!!!!!!&
#!!%@ !% @ @ @!!!!!!% @% @ @!!!!!!!!!!@ @!!!!!!!!!!&
@!!!!!!!!!!@ @!!!!!!!!# @!!!!!!!!!! @!! @ @!!!!!!!!!!@ @!!!!!!!!!!&
@!!!!!!!!!! !!!!!# @!!!!&!!!! @!! @ @!!!!!!!!!!% @!!!!!!!!!!%
@!!!!!!!!!!! &!!!!!!@ @!!!!&# !!! @!!% @!!!!!!!!!!@ @!!!!!!!!!!#
!!!!!!!!!!%!!!!@!!!!!!!!!!% @!!!!&#@!!! @!!%!!!!!!!!!!!!!!!!!!# @!!!!!!!!!!!!!!!!!!!!!!
!!!!!!!!!!&#@!!!!&#!!!! @!!!!&#!!!!& @!!!!@!!!!&!!!!% @!!!!!!!!!!!!!!!!!!!!!!
@!!!!&!!# #!!!!&!!@ !!!!!@!!!!!!!!!!@ @!!!!@!!!! #!!!!@ &!!!!!!!!!!!!!!!!!!@
@!!!!@! @ @!!!!!!!!!!!!!!!!!!@!!!!!!!!!!@ @!!!!!!!!!!@ @!!!!@ #%!!!!!!!!!!!!!!!!!!%
@!!!! @!@!!!!%!!!!!!!!!!@!!!!&!!!!&@!!!!!!!!!!!!!!!!!!& @!!!!!!!!!!!!!!!!!!
!!!!!! #@!!!!@##@!!!!@!!!!& @!!!!&@!!!!#&!!!!!!@ @!!!!!!!!!!!!!!!!!!
!!!!!! #!&# !!!!!!!!!!!& !!# @ @ %!!!!&&
@#@ # @#
@!!!!!!!!!!& !!!!!!!!!!! &!
@!!!!!!!!!!& !!!!!!!!!!!%# &!!!!&@
@!!!!!!!!!!@ @!!!!!!!!!!& @!!!!!!!!!!@
@!!!!&%!!!!@!!!!!!!!!!& @!!!!!!!!!!#
@!!!!&@%!!!!@!!!!!!!!!!@ @!!!!& &!%& &!!!!!!#
@!!!!!!!!!!@!!!!!!!!!!@ !!!!!&!!!!!!!!!!!!!!!!!!@ !!!!!@
@!!!!!!!!!!@!!!!!!!!!!#!!!!!!!!!!!!!!!!!!@ &!!!!%
@!!!!!!!!!!&!!!!!!!!!!%&!!!!& @&!!!!@%!!!!&
@!!!!!!!!!!@!!!!!!!!!!&!!!!@&!!!!@!!!!!!!!!!@
@!!!!&@!!!!!!!!!!@!@#@!!!!!!!!!!@!!!!!!!!!!@&!!!!!!#
@!!!!&%!!!!@!!!!@ @!!!!&!!!!!!!!!!& @!!!!!! @!!!!%
@!!!!!!!!!!%!!!!!!@ @&# @@@!!!!@ &!!!!@ @!!!!%
@@@@ #@@@@ @# @# @@@@##
```

Super Mario Bros. 3  
For the NES  
FAQ/Walkthrough

By Ryan Harrison  
rharrisonfaqs(at)gmail.com

Last Revised: 01 January 2006  
Version 1.1

This document is Copyright (c)2003-2006 Ryan Harrison

=====

# Table of Contents

- 1. Guide Opening
  - 1.01 - Version History
  - 1.02 - Introduction
- 2. Game Overview
  - 2.01 - Story
  - 2.02 - Controls
  - 2.03 - Characters
  - 2.04 - General Tips
  - 2.05 - Basics
  - 2.06 - Moves and Attacks
  - 2.07 - FAQs
- 3. Walkthrough
  - 3.01 - World 1 - Grass Land
  - 3.02 - World 2 - Desert Land
  - 3.03 - World 3 - Water Land
  - 3.04 - World 4 - Giant Land
  - 3.05 - World 5 - Sky Land
  - 3.06 - World 6 - Ice Land
  - 3.07 - World 7 - Pipe Land
  - 3.08 - World 8 - Dark Land
- 4. Enemies
- 5. Bosses
- 6. Items
- 7. Secret Areas
  - 7.01 - Mario Bros. Mini Battle Game
  - 7.02 - Warp Whistle Locations
  - 7.03 - White Mushroom Houses
  - 7.04 - Coin Ship
  - 7.05 - Card Game Solution
- 8. Secrets
- 9. Guide Closing
  - 9.01 - Credits
  - 9.02 - Legal Disclaimer
  - 9.03 - Contacting Us

=====  
1. Guide Opening  
=====

The opening notes to my Super Mario Bros. 3 FAQ.

-----  
1.01 - Version History  
=====

Version 1.1 - 01 January 2006 - The new look for this FAQ, and the Legal Disclaimer has been updated for the new year, and I cleaned it up a bit too.

Version 1.0 - 12 May 2004 - The first fully finished version of this

guide is now ready to post! After the many compliments and questions I got about the guide, thanks everyone for E-Mailing, and I hope you like this new version. Also, allowed Neoseeker to use this guide (I hope you guys are keeping a tab on my latest work, thanks for doing this for me BTW), and now the guide is entirely complete in its beauty. Enjoy this new version!

Version 0.99 - 05 August 2003 - That's it! The entire FAQ is all finished! I have labelled this guide version as 0.99 because I want to update the format later (currently just a draft format), and make a few more updates to some sections, but in its current state, this FAQ is just about complete, and my biggest FAQ ever, as of this date. Whew!

=====  
1.02 - Introduction  
=====

Super Mario Bros. 3 is probably the best side-scroller Mario has seen on the NES. SMB3 has a lot of praise to its name and is the best-selling standalone NES game ever, with a staggering 15 million copies. It has also been re-released on the Game Boy Advance as the main game of Super Mario Advance 4, proving that Mario's touch is still there after 15 years!

=====  
2. Game Overview  
=====

This section of the FAQ is going to mainly describe the basic aspects of Super Mario Bros. 3: Controls, attacks, and using items to their fullest advantage. First-time players or novices or anyone who is new to the game should check this section out before playing.

=====  
2.01 - Story  
=====

(Story obtained from instruction manual)

A message from Mario  
-----

"Hello! How have you been? It's been such a long time since we've seen each other. Bowser is up to his old tricks again, so Luigi and I are going on another adventure. You're welcome to come along."

"This time it's Super Mario Bros. 3, the latest in the Super Mario Brothers series. You'll experience lots of excitement as your journey unfolds. For beginners and seasoned veterans of our previous games, this one is going to be a lot of fun! Let's look at Super Mario Bros. 3 in a bit more detail."

Bowser is back!!!

-----

"Ha Ha Ha! These are my 7 children that are going to help me take over the Mushroom World!"

These are Bowser's kids!!

"We just love being mean!!"

- Larry Koopa
- Morton Koopa Jr.
- Wendy O. Koopa
- Roy Koopa
- Iggy Koopa
- Lemmy Koopa
- Ludwig Von Koopa

### Story

-----

The Mushroom Kingdom has been a peaceful place thanks to the brave deeds of Mario and Luigi. The Mushroom Kingdom forms an entrance to the Mushroom World where all is not well. Bowser has sent his 7 children to make mischief as they please in the normally peaceful Mushroom World. They stole the royal magic wands from each country in the Mushroom World and used them to turn their kings into animals. Mario and Luigi must recover the royal magic wands from Bowser's 7 kids and return the kings to their true forms. "Goodbye and good luck!," said the Princess and Toad as Mario and Luigi set off on their journey deep into the Mushroom World.

"We took 7 wands from the 7 kings. Each of us has one. Our father has instructed us to protect the wands."

=====

### 2.02 - Controls

=====

- D-Pad - Move Mario around on map screen; swim in water with Frog Suit; move about on level screen (Left/Right); climb vines; enter doors; enter upside-down pipes (Up); descend vines; enter pipes (Down)
- Select Button - Highlight different game modes on the logo screen
- Start Button - Confirm the type of game you wish to play from the logo screen; pause/resume game
- B - Pick up shells; open chests in Toad's House; run while moving (filling up the P-Meter more as you run); swing the raccoon tail (when you have the Super Leaf or Tanooki Suit); throw hammers (when you have the Hammer Brother Suit); flick fireballs when Fiery Mario; on map screen flip bottom bar to view your inventory
- A - Jump; bob up when swimming; pick cards in Toad's House; choose items from your inventory; enter stages from the map screen; stop sliding pictures in the Sliding Picture game

=====  
2.03 - Characters  
=====

Mario

-----

He's the most popular video-game character of all time, and he's back, better than ever, and ready to kick some Koopa Tail in another classic adventure! You will control Mario in a 1-Player game, or Player 1 will control him in a 2-Player adventure. Mario wears a red shirt and blue overalls.

Luigi

-----

Mario's brother. Luigi possesses the exact same skills as Mario, it's only his look that's different. Luigi is slightly younger than Mario, a tad taller and slimmer. Luigi only appears in 2-Player games. He wears a green shirt and blue overalls. Player 2 controls Luigi.

Princess Toadstool

-----

Although she's only waving goodbye to you at the beginning of the adventure, she gets more involved as the game progresses...

Toad

-----

Toad makes several appearances throughout SMB3, and can be a great asset to you throughout the game. You can visit him in his house where he can provide you an extra item for your journey, or he will let you play a game-show like mini-game where you must line up the pictures correctly. He also lets you play a card game for rewards, too. He's the Mushroom Retainer of Princess Toadstool and is loyal to the Mushroom Kingdom.

Mushroom Kings

-----

There are 7 Kings throughout the Mushroom World, and each of them possesses a magic wand. Unfortunately, the Koopalings steal their wands to turn them into animals. Your job is to return them to their normal, old selves.

=====  
2.04 - General Tips  
=====

- Try to use suits to their fullest advantage. Remember that the surroundings of Mario can determine which suit is best to carry around. In sky areas it is best to have a Super Leaf or Tanooki Suit to safely hover around in high areas. In watery levels it is best to wear a Frog Suit. If you are carrying anything helpful with you, check your inventory before entering a level.
- Know your enemies. Every different enemy is independent but there are several ways of killing them. Remember, not all enemies are destructible, but remember how best to kill each one.
- Carry around as many spare items as you can at once. Before entering an area make sure you are well equipped. Or if you die in a level see if you have any helpful items that could get you through the next time.

- Explore as much as possible, but remember that you have a time limit. It is always a good idea to check for hidden secret areas within a level, but try to be as quick as you can, or your timer will elapse wasted time.
- Don't take risks. If you are in a spot where you think taking a chance will pay off, don't be so hasty. Try to see if you can work your way around it.

=====

2.05 - Basics

=====

The Map Screen

-----

You start each world on a map screen to direct to each level, as well as other features that can help, such as shortcut warp-pipes, Toad's House, bridges, castles, etc. Each world in this FAQ has a map and key included.

Level Layout

-----

Super Mario Brothers 3 is a side-scrolling game. The general rule is to advance to the right to get to the end of the level and get the card.

Cards

-----

In the bottom right-hand corner of the screen are three boxes. After finishing each level you are given a card. The card's symbol appears in the box. Once you have three cards you are given a prize. If you have three Mushrooms, you'll get 2-Up. If you have three Fire Flowers, it's 3-Up. Five Starmans will earn you a 5-Up. If you have a mixture, you'll get 1-Up.

Fortresses

-----

Each Fortress has different puzzles to solve, but you'll face Boom-Boom at the end of each Fortress. Boom-Boom can sometimes have different attacks, though.

Suits

-----

Each suits have their own special use. Please refer to the 'Moves and Attacks' section for more detail on how to execute them.

P-Meter

-----

When you run, this meter at the bottom of the screen will charge up until the (P) starts flashing, at which you can reach maximum jump height, and you can temporarily fly with a tail should you have one.

=====

2.06 - Moves and Attacks

=====

Combining basic controls can build up to secondary, more complex moves, which can come in very handy during your adventure. Here is a list of moves and how

to perform them. Also, this may depend on whether you are regular Mario or Super Mario, and sometimes depends on the suit Mario is wearing. That will of course be notified, though.

### Flying

-----

Note: You need to have the Super Leaf or Tanooki suit to perform this move.

Find a large gap of space and start running and keep running until the P-Meter is full. Then start tapping the A Button to hover in the air temporarily.

### Gliding

-----

Note: You need to have the Super Leaf or Tanooki suit to perform this move.

Jump into the air and keep tapping A. You will fall to the ground slower.

### The Shell-Dozer

-----

Kick a shell and follow it. The more enemies you knock down, the more points you will accumulate until you start achieving 1-Ups. Be careful not to be hit by the shell if it rebounds off something!

### Bowling

-----

If you find a steep surface like a hill, press Down and Mario will automatically slide down it. If there are any enemies in your path, they will simply be ploughed out of the way!

### Mario Statue

-----

Note: You need to have the Tanooki Suit to perform this move.

Press Down and B Button. Mario will temporarily become a stone statue and enemies will simply walk past him. You can do this in mid-air, and he'll come down to the ground with a lot of force!

### Multiple Attack Points

-----

Jump on an enemy's head and bounce off. When you land on another enemy's head you'll get more points. If you eventually bounce on enough enemies you can get 1-Ups.

### Tail Attack

-----

Note: You need to have the Super Leaf or Tanooki suit to perform this move.

Press B and Mario will swing his tail. Any enemies who get caught by the tail will be wiped out.

=====

=====  
Q: Is there any actual particular difference between Mario and Luigi in this game?

A: None at all. Luigi is exactly the same as Mario, only he's controlled by the second player if you're in a 2-Player game. Anything in this guide that refers to Mario can apply to Luigi as well.

Q: Do you have to play through every single level or are there shortcuts?

A: You can skip a few levels in some worlds, and you can also use Warp Whistles to warp to another world. You can get from World 1 to World 8 by using 2 Warp Whistles, by the way. Check out the Secret Areas section for more information on this.

Q: Can you save your progress in this game?

A: Nope, sorry. You need Super Mario All-Stars or Super Mario Advance 4 to be able to do that.

Q: Hi, I'm from CheatCC...

A: Go away.

=====  
3. Walkthrough  
=====

OK. If, by any chance, this is your first time playing Super Mario Bros. 3, I suggest reading the above information to get used to controls and to know the basics of the world of SMB3.

Another note: There are several strategies to complete a world map, and to finish levels. I'm going to provide all of my known routes to completing the levels, and all levels on the map to get through. However, you can use several different strategies to finish a world map without having to go through some levels.

Another thing, when I am addressing the walkthrough for a level, I am explaining as though you are not using any items to cheat, and if you are Super Mario, what the power-ups in the blocks are. It may be slightly different if you are not using this walkthrough in this kind of way.

Have fun! :)

=====  
3.01 - World 1 - Grass Land  
=====

Map

---

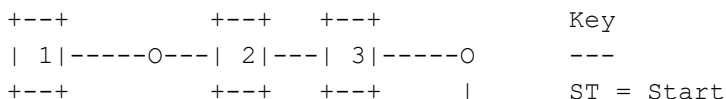



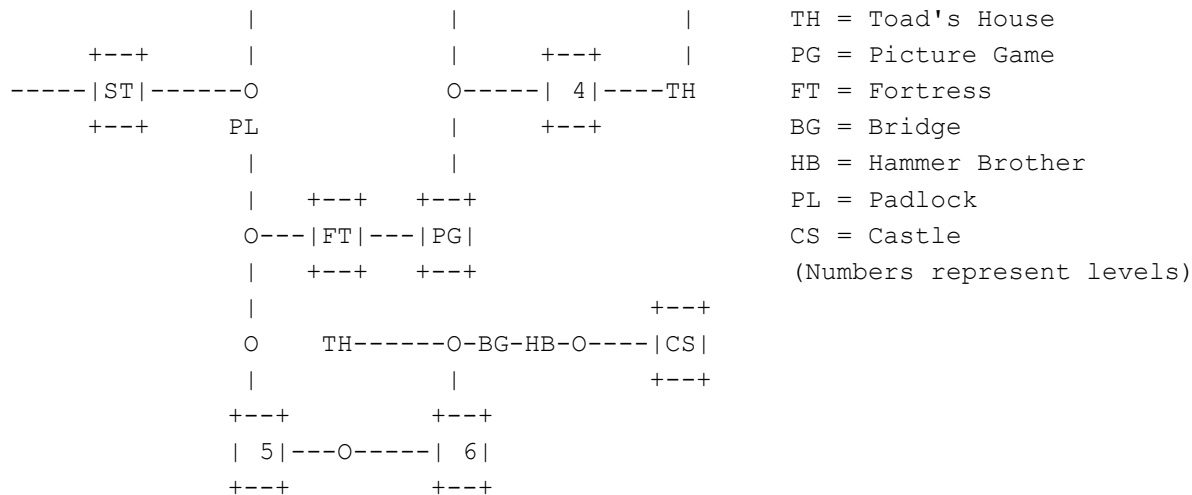

NOTE: The padlock disappears once you complete the Fortress level.

### World 1-1

-----

Let the adventure begin! Run right and stomp the Goomba. The first two '?' Blocks you come to both contain coins. To the right, there are two more '?' Blocks in the air above the pink platform. The one on the left contains a coin, and the one on the right holds the first Super Mushroom of the game. Grab it. Jump over the pipe with the Piranha Plant in. The next '?' Block contains a coin. On the next green platform is a Red Koopa Troopa. Stomp it and kick the shell to the right to hit the '?' Block on the ground, to reveal a Super Leaf. The '?' Block to the right has a coin in it. Go right, and kill the two Goombas and Para-Goomba to clear the runway. There are two optional routes to take to complete the level here...

#### Route 1

-----

Using your newfound Raccoon Tail, run right until the P-Meter fills. At the end, jump, and start flying up the trail of five coins. You'll come to a pink platform in the air. Land here, and get the three coins in the air. Jump onto the little cloud platform to the right, and hit the brick block for a hidden 1-Up Mushroom. Now jump onto the next cloud platform to the right, and grab all the coins in the air above it. Now get a good run up and fill the P-Meter, and jump off the very right end of the platform (get the zigzag formation of five coins if you wish, but you may want to get another charge up after this) and keep flying to the right and stay near the top of the screen. You'll come to a tall green pipe hanging about in the air; enter it.

You'll drop into a dark room with a cluster of coins shaped like a '3'. Get the coins, climb the staircase and exit via the pipe in the ceiling at the right end of the room.

You'll emerge out of a green pipe to the right of a gap between two pipes with wooden blocks on the end. (Scroll down to end of Route 2 to carry on with walkthrough.)

#### Route 2

-----

If you're not much of an airborne person and prefer to travel on ground, then start by jumping over the pit. To the right is a green platform, a pink platform and a blue platform stacked like a staircase. There are three Green Koopa Paratroopas here, but the best thing to do would be to avoid them. Kill or avoid the Green Koopa Troopa on the ground. The '?' Block to the left of



## World 1-3

-----

Run right, stomp the Green Koopa Troopa and pick up its shell. Carry it to the right and use it to take out the Boomerang Brother. Carry on right and you will come to a cluster of brick blocks, music note blocks, '?' Blocks, and you should see a Red Koopa Troopa on top of the highest row of bricks. Stomp it, and kick the shell to the left so that it hits the higher music note block, and it will take out some bricks and get the coins from the '?' Blocks, and creates a gap. The arrangement of bricks you are on now should be shaped like a backwards 'C'. The brick on the highest row, second from left, is a multi-coin block. On the bottom row of the bricks, the brick on the very left is actually a disguised block, which contains a Super Mushroom/Super Leaf.

There are two routes you can take here to complete the level...

### Route 1

-----

Stand one block space to the right of the 2x3 cluster of bricks to your left. Jump up and you should reveal a Red Music Note Block. Jump onto it and press A as you spring up (as you would a trampoline in SMB) and you should go rocketing into the sky.

In this cloudy area you'll see some clusters of coins floating in the air in zigzag patterns. If you have a Raccoon Tail, take a long run to fill up the P-Meter then start flying when you come to about the third zigzag formation of coins. You should see a brick in the air surrounded by a circle of coins. Bump the brick from underneath and a hidden 1-Up Mushroom will emerge. Grab it, and fall back down to the cloud ledge. Finish grabbing the rest of the coins, and go down the green pipe at the end of this area. (Scroll down to end of Route 2 to carry on with walkthrough.)

### Route 2

-----

If you don't take the red music note, then just head right as usual. There is a wooden platform in the air, and a Green Koopa Troopa below it. It would be best to ignore the Koopa. To the right is a wooden pillar four blocks high. Jump over it and stomp the Goomba. To the right is another wooden pillar, three blocks high. If you touch the top block from the side, a Super Leaf will pop out. Now go past the pillar, and kill the Red Para-Goomba. Grab the three coins in the air, jump over the next pillar, and grab the next three coins. Jump over the final wooden pillar, and jump over the gap in the ground. Kill the Boomerang Brother. Go right, jump over the next gap, and two Goombas will approach you; kill them if you wish. Grab the coins on the pink and blue platforms.

NOTE: There is a secret cheat here to get a Warp Whistle. See the Secret Areas section for more info!

Head right and avoid the Para-Goomba.

Routes join up here

-----

Head right into the dark, get the card, and finish level 3.

## World 1-4

-----  
When the screen scrolls right, jump onto the first platform of bricks. From here, jump onto the moving platform and grab the three coins if you can, and quickly jump onto the next brick platform. Get the three coins in the air, and use the moving platforms to reach the lower brick platform. There is a secret 1-Up Mushroom here.

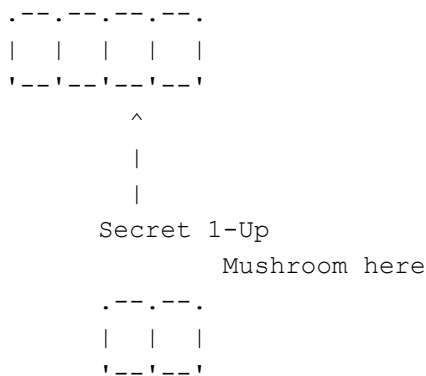

From here, jump onto the moving platform, then over to the 'L'-Shaped formation of bricks, and get the three coins in the air. Jump over to the next 'L'-Shaped formation of bricks and get the 3 coins in the air above that too. There is a hidden Super Leaf in the next 'L'-Shape. To the right of it is a brick platform with a Red Koopa Troopa on it. You can kick its shell at the brick, or hit it from underneath using the platform below.

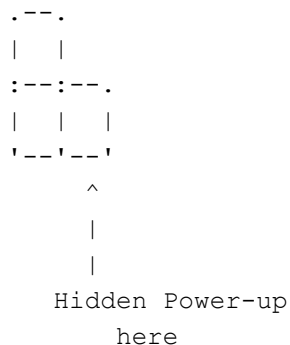

From there, jump onto the moving platform halfway up the screen, and from there, jump onto the brick platform near the top of the screen. If you have the Raccoon Tail, whip the brick on the end that is sticking up, and grab the 1-Up Mushroom that comes out. Now use the moving platforms to grab the coins in the air and get onto the next brick platform. To the right is a vertical line of 8 coins, and a moving platform. When the platform is in the course of the coins, jump onto it so you can swipe the coins as you fall. Remember to jump onto the 'L'-Shaped brick platform before its hits the bottom of the screen! Above, you should see two stacked bricks in the air, the top one is a multi-coin block, but you can only reach it if you are Super/Raccoon Tailed/Fiery Mario. From there, use the moving platforms to reach the 1x3 vertical and horizontal brick platforms. To the right is a Red Koopa Paratroopa with three coins above it. Grab the coins if you're careful. If you're Raccoon-Tailed Mario, you should safely bounce on the Koopa Paratroopa's head, but I'd strongly suggest not bouncing it if you do not have the tail. To the right is a green pipe; go down it.

You will arrive in the darkness area, go right and snag the card to finish the level.

Head right and ascend the stairs. Jump over the lava pit and watch out for the Podoboo. Cross the next lava pit, and from the highest point of this platform, jump over onto the steel platform with the '?' Block in the air above it. The '?' Block holds a Super Mushroom/Fire Flower. Now jump over the other side of the lava pit. Run through the tunnel and watch out for the Roto-Disc. Jump up the stairs and watch out for a second Roto-Disc. The next lava pit has two Podoboos in it, so jump across when you feel it is safe. Then jump onto the next steel ledge (watch out for the Roto-Disc). From here, cross the final pit. The '?' Block here contains a Super Leaf. A Dry Bones will approach from the right, stomp it to prevent it from bothering you.

NOTE: Here there is another chance to find a second Warp Whistle. For more info, check out the Secret Areas section!

Go right and through the door.

This next room has a crushing spiked ceiling. From the start, find the gap in the ceiling and stand directly below it so you are not harmed as it falls. When the ceiling goes back up, jump over the pit and onto the little island, then quickly jump over the second pit and run right to the other end of the room, where there is a gap in the ceiling. As it comes down, duck, and you will not get hurt. As the ceiling goes back up a door will emerge from the floor; enter it.

Run to the end of this room where you'll find Boom-Boom. When you approach him, he'll jump up and start running around. You can kill him with three stomps, five fireballs, or a combination of stomps and fireballs. When he vanishes, grab the crystal to open the padlock on the map.

#### World 1-5

-----  
You start the level sliding down a tunnel and killing four Buzzy Beetles in the process. You then fall into a shallow pool. Grab the five coins here. Go up the hill and you'll come to a Piranha Plant popping in and out of a pipe in the ceiling. Kick the Buzzy Beetle's shell at it, or just run past when it retreats into the pipe.

Level divided into two routes here...

#### Route 1

-----  
You can jump onto the ledge and run along to an overworld area.

NOTE: At the mouth of the cave that leads into the overworld, you can find a Red Music Note Block against the left wall.

```

      |           |
      |.---.     |
      / | |      /
      / '---'<---/-Hidden Red Music Note Block here
-----'         /
                   /
-----'         '

```

This block leads to a coin heaven identical to the one in World 1-3. Check the walkthrough for that level for a brief description of this coin heaven.

Jump out of the underground area and head right. In the small pit are two Green Koopa Troopas, kill them or avoid them. Head right and cross the pit

leading into the underground.

(You arrive here if you went to the coin heaven)

(Go to end of Route 2 walkthrough to continue with level walkthrough)

### Route 2

-----

If you go underneath the ledge, head right and you'll come to a pool with five coins. Get the coins, and continue progressing right. Go past the two little pools and you'll come to a slightly bigger pool with a '?' Block bobbing on the surface. It contains a Fire Flower (if you are Super Mario). Get it if you wish, and head up the slope and into the overworld.

### Routes join up here

-----

Down the next slope is a Green Koopa Troopa. Kill it if you want. Go down the pit, but watch out for the fireball-emitting Piranha Plant at the end of the slope. Go past the two pipes and you'll see a pipe hanging from the ceiling with a Piranha Plant poking its head out. Get past it and exit via the pipe in the ceiling at the end.

You emerge next to the dark area, so head right and grab the card to finish off this ridiculously easy level.

### World 1-6

-----

Jump across the 'T'-Shaped platforms. On the third one is a Red Koopa Troopa and three coins. Kill the Koopa, get the coins and jump down to the platform with the '?' Block above it, which holds a Super Leaf. Then jump on top of the block and onto the next high 'T'-Shaped platform. To the right is a platform moving up and down a 'Z'-Shaped wire. Carefully jump onto it, and use the music note blocks to the right to reach the next platform. Jump over the Red Koopa Paratroopa and onto the ledge with the cluster of bricks. Stomp the Koopa and kick the shell so it breaks the bricks on each side (be sure to keep out of its way!). Look at the diagram for locations of the 1-Up Mushroom and hidden blocks.

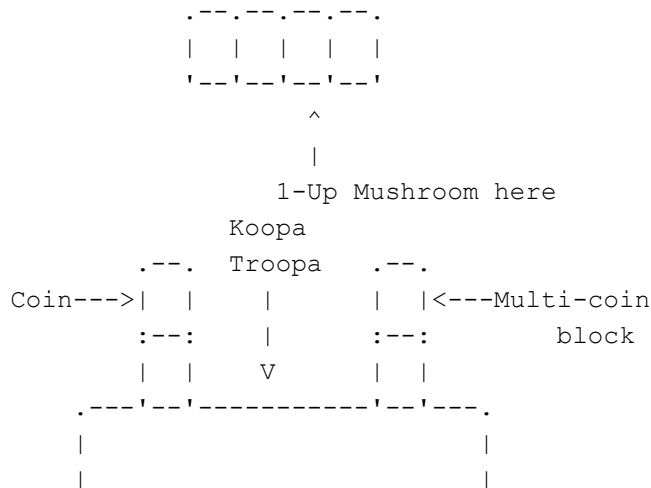

Leap onto the next platform and use the grass hill on it to reach the wooden ledge being held up by ropes at the top of the screen. Jump onto the 'T'-Shaped platform and drop down onto the wooden block. Jump onto the platform on the wire. You are carried right but when you come to the point with two coins above



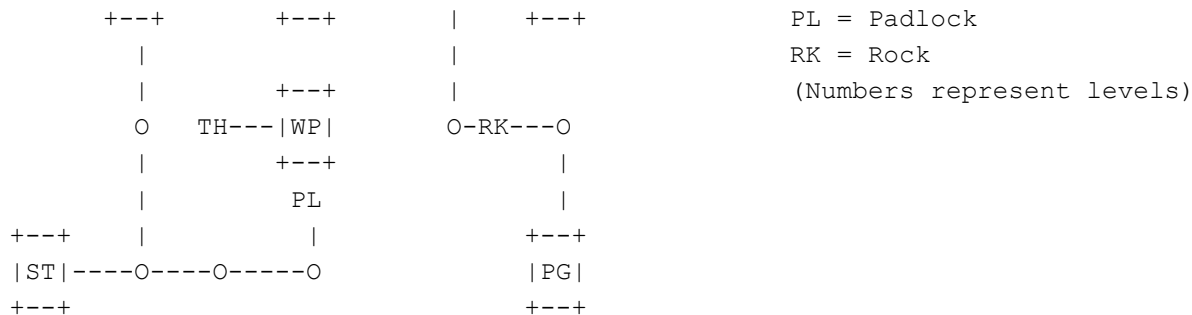

PL = Padlock  
 RK = Rock  
 (Numbers represent levels)

NOTE: The Rock can be taken out using a Hammer.  
 NOTE: The Padlock disappears once you complete the Fortress level on map screen Part 2.

Map - Part 2/3

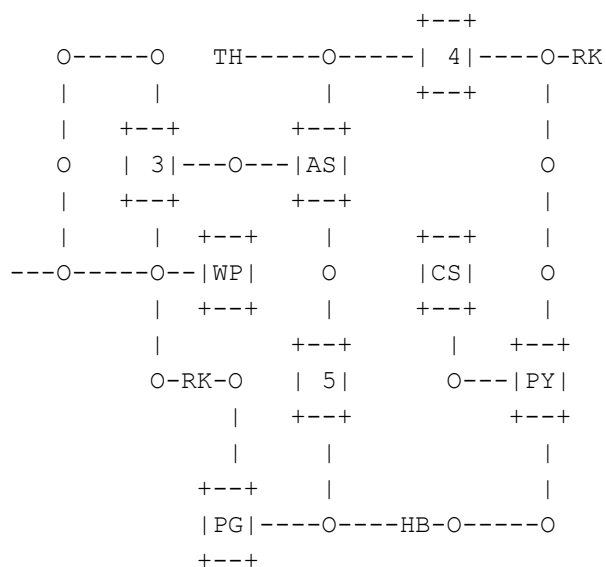

Key  
 ---  
 TH = Toad's House  
 PG = Picture Game  
 HB = Hammer Brother  
 AS = Angry Sun Level  
 RK = Rock  
 PY = Pyramid Level  
 WP = Warp Pipe  
 CS = Castle  
 (Numbers represent levels)

Map - Part 3/3

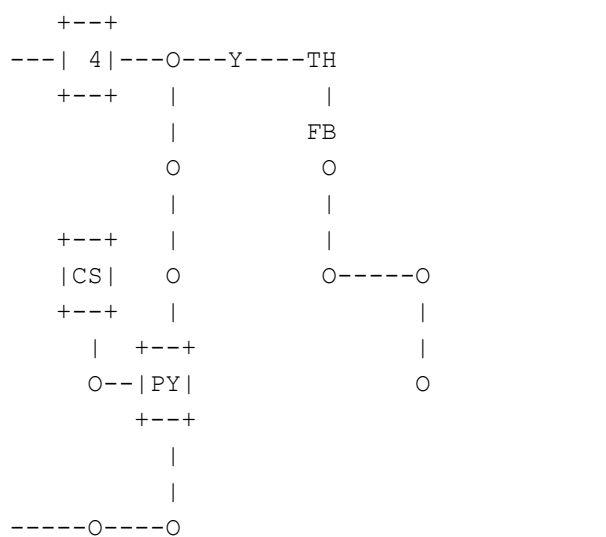

Key  
 ---  
 TH = Toad's House  
 FB = Fire Brother  
 PY = Pyramid Level  
 CS = Castle  
 (Numbers represent levels)

NOTE: You get a Warp Whistle for defeating the Fire Brothers.

World 2-1

Start off by heading right, and you'll come to a cluster of bricks. Be aware that some are Pile-Driver Micro-Goombas. The '?' Block between the two clusters



of bricks holds a Super Leaf. After here, you've got to go past three brick pillars, and watch out for the Pile-Driver Micro-Goombas that are lurking atop each pillar. There are two '?' Blocks next to the third brick pillar. The first one holds a coin, the other a Starman, so grab it! Kill or avoid the Red Koopa Troopa walking about on the ground. Jump over the brick and head right. Use your invincibility to kill the Pile-Drive Micro-Goomba and Firesnake. Past the next brick on the ground are two Music Note Blocks in the air. Use them to get atop the metal structure and kill the Goombas if you want.

Two optional things to do here. If you have a Raccoon Tail, get a run-up and fill the P-Meter then fly into the air about the left-hand side of the metal structure, and you should see a red pipe atop some wooden blocks in the air, surrounded by bricks. Fly into the bricks from underneath to smash them and get into the pipe.

In this dark room is a P-Switch on the floor. Step on it. Sixteen white coins appear in the air; quickly grab them. Then exit via the pipe and you'll arrive at a second metal structure (scroll to the \*\*\* to carry on with the walkthrough).

If you don't want to take the pipe or are not able to, then drop off the pipe at the right-hand side. To the right are two wooden blocks in the air that separate the first metal structure from the second. Jump straight up in between them to reveal a hidden music note block. Jump on the block and bounce over towards the wooden block to the left and hit it on the side. A Super Mushroom or Super Leaf will pop out. Now that you are in Super Mario state, go back to the left metal structure and hit the lower brick to create an entrance inside the structure. Go inside to get four coins and hit the centre brick to get a hidden 1-Up Mushroom, but watch out for the Firesnake! If you are Raccoon-Tailed Mario, whip it with the tail attack to take it out. Now get out of the structure and go over to the next metal structure to the right, the same way as you did the first one.

\*\*\* Get inside the structure either by breaking the brick to make an entrance on the bottom right-hand side of the structure, or if you hit the P-Switch in the secret room and it is still in effect, the bricks in the top should be turned into coins and you can simply drop in. There are 23 coins inside the structure. Once you've got them all, get back out and go right. You'll come to two pipes with Piranha Plants and lots of bricks between them. One of the bricks is a Pile-Driver Micro-Goomba, so be on your toes. Go past the pipe-and-brick set and into the dark area to get the coin and finish off the level.

## World 2-2

-----

Start the level by going up the hill and stomping the Goomba. Go right and cross the quicksand pit with Piranha Plant in it. Up at the top of the next slope is a wooden block. Touch it from the side for a Super Leaf. Now cross the pit and get the 3 coins if you're careful, and land on the green pipe. Cross the next quicksand pit, but watch out for the Piranha Plant inside the pit; it shoots fireballs. Now jump over the small wooden block stump and onto the platform. It'll carry you to the right, over the big river. Past the Green Koopa Paratroopa are three coins in the air. Then two brick blocks; the second one holds a P-Switch. After that are four more coins and six brick pillars you have to jump over. Then jump over the Green Koopa Paratroopa then a large brick pillar four bricks high. You can then safely drop to the ground and enter the pipe.

You'll emerge next to the dark screen. Head right and grab the card to finish

this really short level.

## World 2 Fortress

-----

Go down the flight of stone stairs. Stomp the Dry Bones and head right. There are two more Dry Bones ahead. Either stomp them or avoid them as you go right. There is a little ledge here and a Thwomp in the ceiling. Stand near to the area where the Thwomp will directly drop. As it flies back up, quickly run right and get through. There are another two Dry Bones ahead, stomp or avoid them and climb the next flight of stairs. Go down the stairs, head right, and you come to another ledge with a Thwomp waiting above. Just to the right of the Thwomp is a Boo Buddy, make sure you keep an eye on it at all times and don't turn your back to it too often. Get up the next flight of stairs and watch out for the Dry Bones descending them. Go up the pipe in the ceiling.

You are now taken to a higher floor of the Fortress. From here, go right and up the next flight of stairs. Stand on the top step and jump over the pit of spikes and onto the stone ledge (watch out for the Thwomp!). Jump over the second half of the pit to the platform made from a stone block and silver brick (which contains a Super Leaf). There is a Boo Buddy here, be aware and keep it away at all times. Now head right, get past the next four Thwomps and enter the door at the end of the tunnel.

This next room has ledges with spikes on the top and bottom that go up and down, and has a few Boo Buddies in the room. When the first set of spikes, two blocks long, raises, quickly run underneath and stop at the gap between this one and the second platform with spikes. Wait for that to fall and rise, then quickly run underneath again. The next spiky platform has some blocks on top. You can use these to cross as it is a bit risky to run underneath because it is a fairly large platform. Do the same for the next spiky platform. After this, you'll see a door emerging from the floor. Enter it.

Run to the end of the room to meet up with Boom-Boom a second time. Just use the same strategy to beat him as you used before: three stomps, five fireballs, or a combination. Once you've got him beat, grab the crystal he drops to open up the padlock on the map.

## World 2-3

-----

To your very right from the start is a pyramid of platforms with a hollow gap in the middle. A Red Koopa Troopa and Firesnake roam around this pyramid, it's just the Firesnake you have to watch out for. On the top of the pyramid are two '?' Blocks on top of bricks. You can get rid of the bricks by hitting them from beneath if you are Super Mario, or use the Red Koopa Troopa shell to smash them so you can reach the Blocks. The '?' Block on the left holds a single coin, and the one on the right has a Super Leaf in it. When you've got everything, jump over the pit to the right, with three wooden blocks in the air above it. The next pyramid you come to has two hollow areas and two Firesnakes jumping around it. There are two '?' Blocks on top of the pyramid, on top of bricks like the first. The one on the left has a coin in it, and the one on the right holds a Starman. This is useful for killing off Firesnakes, but use it wisely and quickly, the effect doesn't last long! After the next gap is a third pyramid, this time with no hollow gaps. There is a Firesnake and two Green Koopa Troopas here, so kill them with your Starman invincibility if you still have it. At the top of the pyramid is another two '?' Blocks on top of bricks. The one on the left has a Super Leaf; the one on the right has a coin. Go past the next pit and you'll come to a fourth pyramid, but this one is made entirely out of brick blocks. You'll see a Green Koopa Troopa descending the pyramid on the left hand

side towards you. Stomp it and kick the shell away. Head to the top of the pyramid, and beware of the Pile-Driver Micro-Goomba that rests atop the pyramid. Okay, there's a hidden 1-Up Mushroom here. You see the wooden block touching the pyramid? Stand beneath that, on the third row of bricks from the bottom. If you have a Raccoon Tail, start swinging. You'll find a hidden block with a 1-Up Mushroom in it, in the middle of the fourth row of bricks. To the right is a second brick pyramid. Go past it, and you'll see a few bricks in the air, watch out for some Pile-Driver Micro-Goombas hiding around. If you have a Raccoon Tail, get a run-up in this area and fly up to find a platform with some coins. Then go back down and head right to a final brick pyramid. Go to the top and drop through the gap at the right-hand wall. Stomp one of the Green Koopa Troopas and kick the shell then get out. The shell will take out the majority of the bricks, and reveals the pipe, which you can now go down.

You emerge at the dark screen area, so proceed to the right, snag the card and finish the level!

#### World 2 Angry Sun Level

-----  
It would be a good idea to use the P-Wing you received at the end of World 1 for this level to fly by easily.

If you want to save it for later/you already used it/you warped here, here's a normal walkthrough.

Jump over the first sand pit. Jump over the next one and watch out for the Red Koopa Paratroopa hovering about at the other side and the Piranha Plant in the sand that spurts fireballs. Now if you go right, you have to cross a HUGE sand pit with two fireball-spitting Piranha Plants in it, so get a good run-up first. Then kill or avoid the Green Koopa Troopa at the other side of the pit. Then run right at full speed and jump straight into the tornado, and you should be spat out the top and you can head on right. Then there's a row of 8 bricks on the ground. Go past them. You'll come to a row of another 8 bricks on the ground. At this point, the Angry Sun will start swooping down at you. You should jump over him when he gets to the lowest point. There is a Green Koopa Paratroopa bouncing around on the third row of 8 bricks. Past the next row of bricks, and a fifth one with another Green Koopa Paratroopa. Then cross the sand pit, go up the high slope, cross the big sand pit, down the other side, into the dark area, and grab the card.

#### World 2-4

-----  
From the very start of this level, there are two routes you can take to complete it.

##### Route 1

-----

If you have a Raccoon Tail, get a run up at the start area and fill the P-Meter. If you look at the left hand side of the ceiling you'll see some bricks. Fly up and smash the bricks to come to a new area. There is a pool with a couple of brick platforms bobbing on the top with 9 coins above. Drop into the pool using the gap between the platforms, and hit the third brick from the left for a P-Switch. Hit it to turn all the bricks into coins, and quickly get as many as you can. Watch out for the Green Cheep-Cheep in the water as well. Then climb out of the pool and get moving right again. Ahead are several pairs of coins, get them all. Then there's a brick platform with more pairs of coins in the air above it. Get them, then go past the two Red Koopa Paratroopas. You then come to some scattered bricks and coins. Hit the

brick on the end of the third level of coins for a P-Switch, and use it to quickly get the coins that are made from the bricks. When they change back, get the rest of the coins, you can jump off the edge down to the ground, and even use the music note blocks for a shorter drop (the last music note contains a Super Mushroom/Super Leaf power-up). Go to the end of the Route 2 walkthrough to carry on from here.

## Route 2

-----

Head right and kill the Red Para-Goomba. The first '?' Block you come to has a coin in it. Stomp the Red Koopa Troopa on the first wood stump and kick the shell away. Cross the pit carefully, and stomp the Red Koopa Troopa on the right-hand stump and kick the shell to the left so that it rebounds off the other wooden stump and hits the '?' Block in the pit for a Super Mushroom or Super Leaf, which is helpful if you don't have one or the other. Then get moving to the right. You can kill or ignore the Red Koopa Troopa on the stone block. It is best you kick the shell, pick it up, and cross the pit to kick at the '?' Block on the ground for a power-up. Watch out for the Boomerang Brother. There are five coins in the air in an arc to get as well. Now go right, kill or avoid the Green Koopa Paratroopa, and go past the stone block with the Red Koopa Troopa on it. To the right is a pit with two wooden blocks hovering in it. Above it are four coins, but if you're going to get them, beware of the boomerangs that the Boomerang Brother throws. After this, cross the giant pit, and hit the '?' Block for a Super Leaf power-up. On the stone block is a pipe with a Piranha Plant in it that shoots fireballs but that shouldn't pose a serious threat. Go past the rest of the stone blocks. Watch out for the Boomerang Brother on the third one. Grab the four vertically laying coins on the side of the first set of stone blocks. Now cross the stone blocks and get the eight coins in between the first couple of gaps.

## Routes join up here

-----

Go right into the dark area. When grabbing the card, watch out for the nearby Boomerang Brother.

## World 2-5

-----

At the very starting area of this level there's a Chain Chomp. So you gotta make a great jump to get over him! If you're brave enough to go for the '?' Blocks, I'll tell you that the one on the left has a coin in it, and the one on the right has either a Super Mushroom or Super Leaf in it. Go right, and use the cluster of platforms to get over the next Chain Chomp. To the right of the Chain Chomp are four wooden blocks in a vertical formation with a few gaps. Touch the bottom wooden block to reveal a Super Leaf. Go through the blocks and ignore the Koopa Troopa and the bricks, and just go right and cross the pit. A Goomba descends the platforms, so stomp it if you must. Remember to stay well above the Chain Chomp. Just remain on the top of the platforms, and kill any Goombas you come to. Then you'll drop onto some wooden blocks. Cross the tiny water-filled gap into the next section of platforms. There are two Red Koopa Troopas here; stomp one and kick the shell to the right so that it hits the brick for a coin. Up next you'll see a couple of formations of wooden blocks with some bricks on the ground. To the right is a nearby Red Koopa Troopa whose shell you can kick into this area to reveal a vine that leads to some secret platforms. Check the diagram to see exactly where it is.

(Bricks on the ground in this area)

```

      .---.---.
      |   |   |
      .---:---:---:
Secret Vine --->|   |   |   |
      '---'---'---'

```

Ok, so climb the vine and at the top, drop left onto the cloud platform. Get the four coins here, jump onto the next platform to the left and get the coins. Carry on jumping across the cloud platforms to the left until you come to a warp pipe, which you can enter.

Stand the bottom brick and jump straight up to reveal a hidden P-Switch. You then just have to find some way to get it; it isn't possible with Regular Mario. Also, the bottom right-hand corner brick contains a Super Leaf. Be sure to get it before you leave (the pipe at the right end of the room).

You'll then emerge out of an upside-down pipe onto a cluster of platforms in the sky. On the top of these platforms are four '?' Blocks. The first three have coins in them; the fourth holds a Super Mushroom/Super Leaf. Then drop off the platform to the ground. Now just move right into the dark area screen and get the card (beware of the Chain Chomp!).

#### World 2 Pyramid Level

-----  
This entire pyramid is made of stone when you start from the outside, but there is a platform you can run through to enter the door. So go inside.

Go up the staircase and jump over the Buzzy Beetle that comes down it. At the top of the stairs is a Buzzy Beetle trapped between two stacks of bricks, and a '?' Block that contains a Super Mushroom or Super Leaf. Now go down the slope and enter the middle tunnel. If you have a Raccoon Tail, you can smash the bricks to advance, or you can kick a Buzzy Beetle's shell at them to smash them and move on. You should come to a pipe. There is a crossroads here. Jump onto the ledge above you to your left. Go to the next opening above you, and you'll see a Buzzy Beetle walking along the right platform, which is the one you need to take. There's another brick wall you need to smash; do the same as last time. You'll see an upside-down pipe in the ceiling surrounded by wooden blocks. Stand three block spaces to the right of the vertical row of wooden blocks, jump up, and you should reveal a hidden block with a coin. Use this to get inside the alcove and access the pipe.

Outside, there are two rows of bricks with coins on them. Hit the lone brick beneath the lower platform for a hidden P-Switch. Hit it so you can access some coins. When they change back, you can get more coins, then exit via the pipe against the right-hand wall.

You'll re-emerge in a different pipe. Head up the slope to your right. In the tunnel you'll see a Buzzy Beetle on the ceiling, which drops and rushes toward you with a spin attack when you come close, and a regular walking Buzzy Beetle. Go past them and you'll see another ceiling walker. You've got to advance past the next brick wall, so use your Raccoon Tail or a Buzzy Beetle shell if you don't have a tail. Then go past the pipe, run along to the end and exit via the pipe in the ceiling.

A Boomerang Brother awaits you here. Kill or avoid it then run right and grab the card for access to the castle!

#### World 2 Castle

-----  
 The king has now been transformed into a spider, and you've got to morph him back using the magic wand. You'll view a small cut scene of Mario or Luigi boarding the airship, and then the level begins.

Start by jumping onto the second Bullet Bill cannon, and jumping onto the high platform. A cannon is attached on the side here, watch out for the cannonballs it shoots. Drop down onto the next part of the ship. Leap over the first Bullet Bill cannon, and go under the one that's on a wooden pillar being upheld by a screw, but make sure there's no Bullet Bills being fired from the cannon to the right. Then jump onto the next part of the ship. The '?' Block holds a Fire Flower (if you are Super Mario). Get it if you want, then jump over onto the wooden boxes and drop down and through them, under the wooden pillar and climb the next load of boxes to reach the next part of the airship. Look out for three Rocky Wrenches that appear here. Now go past the next two cannons and enter the silver pipe. For help on beating the boss here (Morton Koopa), please look at the Bosses section of this FAQ.

So you're returned to the castle, the king is himself again, and you receive another letter...

```

+-----+
| Greetings,          |
|                    |
| You can stomp on   |
| your enemies using |
| Goomba's shoe.    |
| I have enclosed a |
| jewel that helps  |
|   protect you.    |
|                    |
|                    |
|           Princess |
|           Toadstool. |
+-----+
  
```

Today's letter gift brings our heroes...a Jugem's Cloud!

```

=====
3.03 - World 3 - Water Land
=====
  
```

MAP - Part 1/5

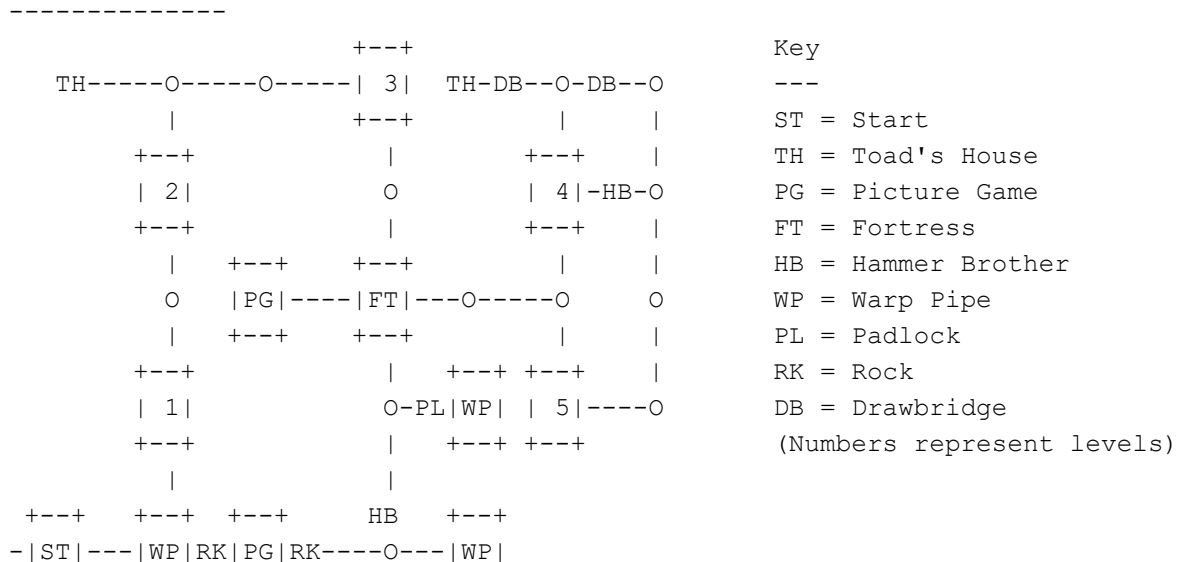

+++ +--+ +--+ +---

NOTE: Rocks can be taken out using a Hammer.  
NOTE: The padlock disappears when you beat the Fortress level.  
NOTE: Drawbridges open when you beat a level. They connect when you beat another level.

Map - Part 2/5

-----

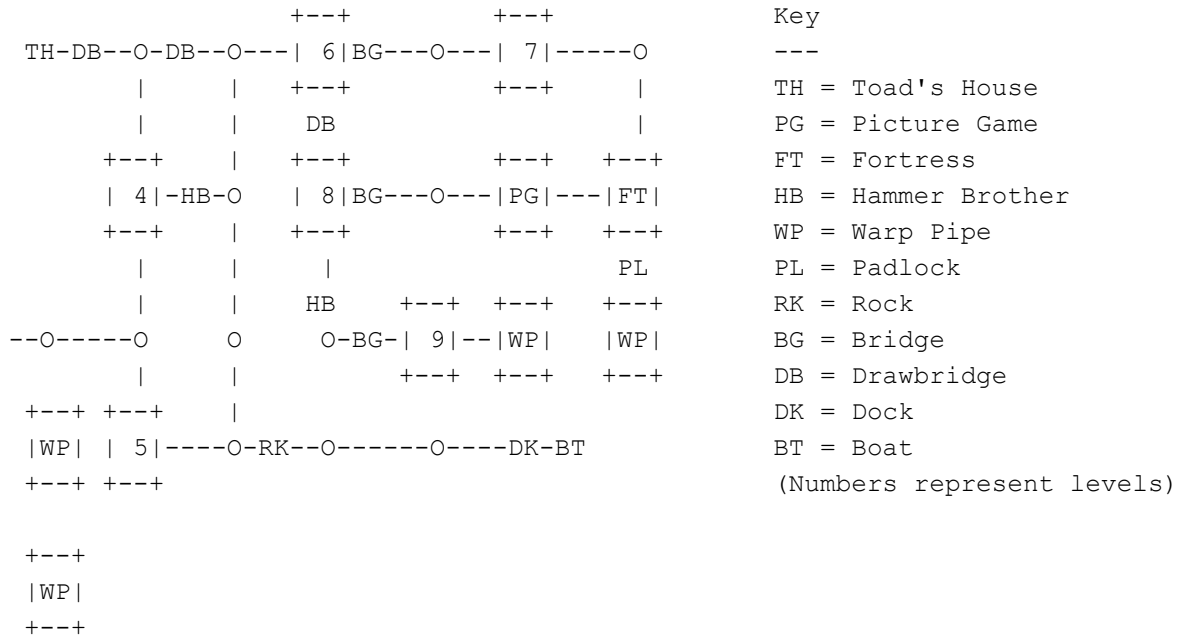

NOTE: You can only board and leave the boat at a dock.  
NOTE: Rocks can be taken out using a Hammer.  
NOTE: The padlock disappears when you beat the Fortress level.  
NOTE: Drawbridges open when you beat a level. They connect when you beat another level.

Map - Part 3/5

-----

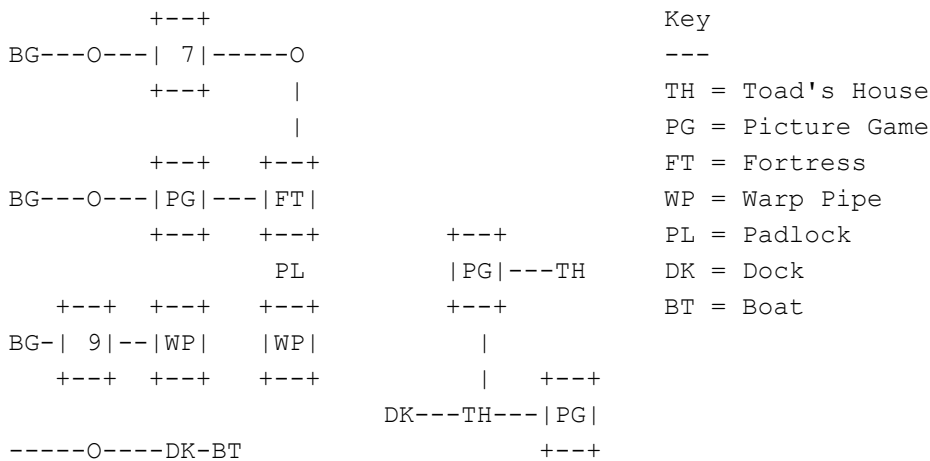

NOTE: You can only board and leave the boat at a dock.  
NOTE: The padlock disappears when you beat the Fortress level.

Map - Part 4/5

-----

DK---TH Key  
---

TH = Toad's House  
PG = Picture Game  
DK = Dock

```
+---+  
|PG|---TH  
+---+  
|  
| +---+  
---TH---|PG|  
+---+
```

NOTE: You can only board and leave the boat at a dock.

Map - Part 5/5

```
-----  
---TH
```

Key  
---  
TH = Toad's House  
WP = Warp Pipe  
DB = Drawbridge  
CS = Castle

```
          +---+          +---+  
DB      |CS|-----O---|WP|  
          +---+          +---+
```

NOTE: Drawbridges open when you beat a level. They connect when you beat another level.

World 3-1

```
-----
```

Water level! Whee! First off all, if you look to the left of your starting position, there's a little gap. Drop down here and you'll see a '?' Block. Swim up to it and bash it for a Fire Flower; grab it. Now go back up to where you started and swim to the right. Go past the coral and the pipe blowing bubbles and watch out for the Blooper. Go past the next pipe and swim downwards when you come to the blue pipe. There's another Blooper down here, kill it with fireballs, or avoid it if you want to play safe. Go past the pipe, and to the right you'll see a Lava Lotus. Grab the 8 coins above it if you're quick, and watch out for the lava balls it releases. Now continue swimming right and go past the blue pipe. You'll encounter another Lava Lotus with two '?' Blocks above it and six coins surrounding it. The '?' Block on the left holds a Fire Flower, and the one on the right holds a coin. However, I suggest not trying to get them, as the rebound from hitting the blocks can make you fall down right onto the Lava Lotus. Now swim up, and right past the blue pipe hanging upside down from the wood. After the pink platform is a Blooper Nanny, avoid! Just continually move right and enter the blue pipe in the ceiling at the end.

Back in the overworld, move right and get the card!

World 3-2

```
-----
```

NOTE: Cheep-Cheep in the water can jump up at you. Stay well above them, and don't fall in!

From the starting ledge, jump right onto the platform moving on a wire in a vertical zigzag direction. Then onto the next one, then jump over to the next platform suspended by ropes. There is a '?' Block in the air between some



falling blocks, which holds a Fire Flower. Now to your right you'll see a wooden platform on the end of the wire. Jump onto it, and it will immediately move you to the right. It'll go past an 'L'-Shaped array of wooden blocks. Then there's three coins in the air, a '?' Block with a coin in it, six more coins, and a Red Koopa Paratroopa. The Cheep-Cheep will start jumping around a lot now, watch out! The next '?' Block has a coin in it. Now the wire goes in a zigzag movement. Above the second zag are three coins; grab them if you want. Then you'll come to the end of the line. Quickly jump onto the two falling blocks and hit the '?' Block for a coin. There is an emergency wooden block bobbing on the water in case you fall in. Now jump onto the next platform on the wire. Get the three coins, and you'll begin moving right. Watch out for more Cheep-Cheep and a Red Koopa Paratroopa on the way. Before the end, there is a brick platform which you can jump on to get three more coins in the air. Use it to safely cross to the warp pipe (watch out for the Piranha Plant).

You'll emerge in another area on a connection of wooden platforms suspended by ropes. Watch out for the Cheep-Cheep lurking around here. Go right and end the level by getting the card!

### World 3-3

-----

Always, always, ALWAYS remember to stay away from Boss Bass! No matter which state Mario is in, a simple swallow will kill him in one. Remember to stay away from jumping Cheep-Cheeps as well! From the start, cross the first large gap, then over the next three little gaps, before another big gap. There's a row of bricks and a music note block, which releases a Fire Flower if you step on it. Just move over to the end of the brick platform and jump onto the next little platform. Jump over to the next, then stand on the stump. Wait for the rotating platform to stop spinning, then jump onto it and cross the next gap onto a platform with two bricks and two white bricks. You can pick up white bricks and kick them at things as if it were a Koopa Shell, although it will break upon contact. If you kick one at the brick on the platform you are on, you can get a hidden P-Switch. See diagram for location.

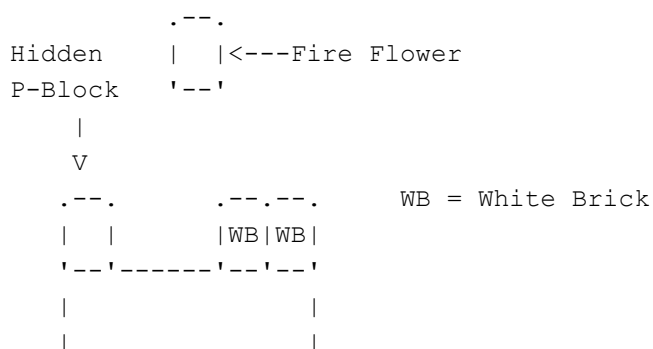

Use the P-Switch to turn some coins into bricks, and quickly cross the huge gaps. Then, at the 'L'-Shaped platform, there should be two bricks in the air to your upper-right hand side. Jump onto them. Wait for the rotating platform to the right to stop spinning, then jump onto it, and from there, jump to the right onto the next 'L'-Shaped platform and enter the pipe.

Jump over the watery gap to the right and head right to finish the level.

### World 3 Fortress (1)

-----

Head right, past the Roto-disc and the Dry Bones. Jump over the column. Then go past the next Roto-disc and up the staircase. Go past the silver pipe, and the Thwomp waiting shortly after it. In this hallway, there is a huge row of doors,



Lakitu appears here! Also, what makes Lakitu more annoying than he was in the original SMB is that he throws the green eggs at an angle, and several at a time. These six lined up bricks are actually disguised blocks. The second one from the left holds a 1-Up Mushroom, and the rest contain coins. Now start crossing the gaps and the little islands. There are then two more '?' Blocks. The one on the left has a coin in it. The one on the right: a Super Leaf. Now run down the slope and get the card to finish the level.

#### World 3-5

-----

NOTE: This is a huge water-filled level. A Frog Suit can come in rather handy here, so you can fish one out of Toad's house if you haven't already got a Frog Suit.

Run off the end of the pipe and dive into the water. Swim directly down and you can get three coins between the coral hoops. Go back up to the surface of the water. Swim past Jelectro, and you'll see a gap of wooden blocks being guarded by another Jelectro, and if you go down a bit, you'll encounter Big Bertha. Stay above her. The three '?' Blocks contain (in order from left to right): a Super Mushroom/Fire Flower, a coin and another coin. The three bricks also have coins. When you swim above the pipe it will blow you up, but watch out for another Jelectro. Go right and under the platform, and you can get six coins. Swim right past the Jelectro, and the upside-down pipe will blow you down, so you can get four coins, but watch out for the pit. Stay at the bottom and continue moving right for some more coins. Then there's a pipe that blows you up, but be careful as there is a Cheep-Cheep above! After it, there is a row of three '?' Blocks, with a Jelectro above and below. The blocks contain a coin, Super Mushroom/Fire Flower, and a coin. Now swim past the two pink pillars and get past the Cheep-Cheep and go down. Swim past the pipe that blows you down, and watch out for the Jelectros to your right. Get past them and you'll come to three coins and a Blooper Nanny, so avoid that! Also keep an eye out for Big Bertha who is floating about here. Swim up, and enter the pipe in the wall.

You're spat out of a pipe in another wall. Now hop onto the wooden platform. Then jump across to the land, run right into the dark area, grab the card and finish the level.

#### World 3-6

-----

NOTE: You have to be able to cross the bridge on the map to access this level, and to do so the bridge needs to be connected. The bridge opens every time you complete a level, and connects when you finish another, and repeats. So if the bridge is open, you need to go back and complete another level.

A scrolling-screen level. Having a Raccoon Tail would really help here. Start by moving right and jumping onto the platform of falling rings. There is a longer platform next to it with a '?' Block above it, which contains a Super Mushroom or Fire Flower. Jump onto the wooden platform and wait for the red platform to stop spinning, quickly jump onto it then jump onto the next platform of falling rings and onto the higher wooden platform to the right to stay safe. Beware of the Red Koopa Troopa. If you have a Raccoon Tail you can drop down to the lower level and swing it against the brick and get the three coins. Moving on right, there is a long wooden platform resting atop of three wooden blocks. Jump onto it. There is a falling ring and white block somewhere in the middle of the platform. You can use the white block to take out the Red Koopa Troopa nearby. Get some coins in the air. At the end of the platform is another wooden platform with a brick on the end, which you could bash if you

had a tail or with the white block mentioned earlier. Now jump over the big pit with the Red Koopa Paratroopa hovering about in it, onto another wooden platform with a brick on. Then prepare to make another long jump onto a wooden platform with a Red Koopa Troopa and brick on it. To the right is another wooden platform with some white blocks beneath it. Jump onto the white blocks. In the block lodged in the platform is a 1-Up Mushroom, but it's a bit risky to go for it. If you are Super Mario you can break some of the bricks in the cluster of 4x2 and jump onto the higher platform, and from there, you can jump onto the platform of falling rings. If you are Regular Mario, you'll have to jump onto it from the bottom. The next part is rather tricky. You'll need to hop around on the platform to stop the rings from falling. When the spinning platform stops spinning, jump onto it (avoid the Koopa Paratroopa) and stay on the right side, above the pipe. When it spins again, you'll drop through. Go down the pipe.

You emerge on a wooden platform. Jump onto the next wooden platform and take care of the Green Koopa Paratroopa if you have to. Then jump right once more to get to safe ground, next to the dark area, where you can proceed to run right, grab the card and finish the level.

### World 3-7

-----  
Right above you when you start is a '?' Block. Bash it to retrieve a coin. Go right and you'll come to three grass platforms with two Spikes on them. Just run past. Cross the pit and you'll come to some more grass platforms and Spikes, go past these too. Then you'll come to a cluster 15 bricks above a single wooden block. There is a hidden 1-Up Mushroom here, but you can only achieve it if you are Super Mario. Here is a diagram (1U stands for 1-Up).

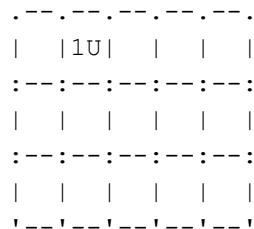

Now carry on right and look out for more Spikes. Jump over the pit and you'll come to a small island with two wooden blocks on each side and a Green Koopa Troopa and Spike. Kill them or avoid them. Jump the next gap. Get over the pipe and jump the next gap. There are a couple of grass platforms here, some brick arrangements, three Spikes and a Green Koopa Troopa. Kill them if you want. There is a vine inside the very left block in the higher row of bricks here. Use the higher grass platform to the left to be able to reach it.

Climb to the top and go left across the cloud platforms, and get the coins. On the longest cloud platform is a brick with a P-Switch inside it. Press the switch and quickly go back down the vine and get some extra coins. Now jump the next gap and get past the pipe with the Venus Fire Trap inside it. There are two grass platforms and a Spike here, get past them and jump over the next pipe, which contains a Venus Fire Trap. Then you come to a big stairway of blue blocks with wooden blocks on the end and some Spikes.

You can touch the second wooden block up on the side for a Fire Flower, and watch out for the Green Koopa Paratroopa descending here. Use your Fire powers to take him out and any Spikes to avoid their spiked balls that they throw at you. Drop down off the edge and run right into the dark area. Watch out for the Spike, and collect the card to finish the level.

## World 3 Fortress (2)

-----  
Jump into the water and descend the pipe.

In this next area, swim through the narrow passageway and past the Roto-Disc and the Cheep Cheep. You'll come to a '?' Block, which holds a Super Mushroom/Fire Flower. Watch out for the Cheep Cheep here, and carry on swimming to the right, past a second Roto-Disc and another Cheep Cheep, and go down the pipe at the end of the room.

You will have to swim very precisely in this next room. Just to the right of the pipe are two Stretches. It's okay to touch them, but not the Boo heads that come out. Once you get past, swim across the gap and you come to another three Stretches. Swim past them and go down yet another pipe.

Run to the end of this room to meet another Boom-Boom. There are two blocks in this room to let you gain air, but also limit your jumping...barely. Stomp, stomp, stomp, fireballs. It's all in the mind. Grab the crystal once you are finished and unlock the padlock below the fortress on the map.

## World 3-8

-----  
Remember to stay away from Boss Bass at all times! If you have a Fire Flower, take him out at any opportunity. Jump onto the high end of the platform you start on, jump two gaps and you'll be on a platform with two bricks and a Green Koopa Troopa. You can kick its shell against the bricks for a vine, and you can climb up it and jump on top of the Music Note Block for a Power-up to fall onto the land below. Drop down and grab it if you need it.

Now jump the gap onto a pillar, then again onto a higher pillar with two white blocks and a brick all piled up. Kick the white blocks away and stand under the brick and jump repeatedly - it is a multi-coin block. Now jump over across the pillars until you approach a platform with three coins and a brick. Grab the coins and jump onto the next platform. There are five coins in the air, which you could grab if you bounce on the Green Koopa's head. Remember to be aware of Boss Bass. Kick the Koopa's shell to get another vine. Climb it and wait for the water to lower.

Drop to the right onto the next platform, quickly get the coins and jump onto the next platform and bash the brick to make another vine appear, and quickly climb it to safely stay away from Boss Bass. The quickly drop down and jump across the gaps and over the pillars until you get to the highest one. Jump on top of the steel formation and run right. Jump over the three bricks and keep going right and enter the pipe.

You arrive on a bridge suspended above water. Run right and drop off at the end to enter the dark area and get the card.

## World 3-9

-----  
Move right and drop off the platforms, and you'll come to three bricks and a Green Koopa Troopa. Go past and you come a large upside-down pipe that has a Piranha Plant occasionally popping out. When it goes inside, go past the pipe. There is a Bullet Bill cannon here, and the Para-Goomba will drop Micro-Goombas, so beware. Run right and you'll have your first encounter with Bob-omb. Jump over him onto the green platform, jump onto the higher white platform to the right and then onto the wooden blocks.

In the four '?' Blocks here are four coins. Now go right, past Bob-omb and drop off the edge. Run right and you'll come to some white blocks and Music Note Blocks. Jump onto the Music Note Block in the middle and kick away a white block so you can achieve the Power-up. Move right and kick the Bob-omb away and grab the three coins. There is a Green Koopa Troopa inside the alcove here. Pick up one of the white blocks and kick it at it to kill it, and then hit the brick above you to get a 1-Up Mushroom. Now quickly get right of some white blocks so you can get out and grab the 1-Up Mushroom.

Get the three coins in the air, go past the Green Koopa Paratroopas and kick away some of the white blocks so you can enter the warp pipe.

You now enter a huge area full of water. There is no use swimming left, so go right and between the wooden blocks. Watch out for the two green Cheep Cheeps. Enter the upside-down pipe to emerge at the dark area, run right and grab the card.

### World 3 Castle

I don't know what the king has been transformed into here, but it looks like a cross between a monkey and a turtle. Anyway, you'll see a cut-scene of Mario or Luigi approaching the airship and climbing up.

When you have control, jump over the pillar just to your right and look out for Rocky Wrenches on the deck. Jump over the Bullet Bill cannon and climb onto the high ledge. Drop down (watch out for cannons) and run through the little passage and jump up onto the next ledge. The '?' Block above the third cannon holds a Super Mushroom or Super Leaf.

Now carefully get through between the four cannons. Jump onto the pillar and do one of two things: use the bolt to get across the long screw by jumping on it repeatedly (if you have a Raccoon Tail you can glide across) or drop down, avoid the flamethrowers and get to the end of the screw.

Now jump onto the pillar at the top of the screen and advance right; watch out for Rocky Wrenches. Jump the next gap where there should be a screw top, climb the steps and drop down through the silver pipe, where you will meet the boss of this world, Wendy O. Koopa. As usual, please refer to the Bosses section of this FAQ if you are in need of any help.

When you return and are greeted by the King, you get another letter from the Princess...

```
+-----+
| Greetings,          |
|                    |
| The White Block    |
| contains magic     |
| powers that will   |
| enable you to defeat |
| your enemies.      |
| I have enclosed a  |
| jewel that helps   |
|    protect you.    |
|                    |
|                    |
| Princess           |
|    Toadstool.      |
```

+-----+

Let's see what our lucky contestants win today...a Music Box!

=====
3.04 - World 4 - Giant Land
=====

Map - Part 1/3

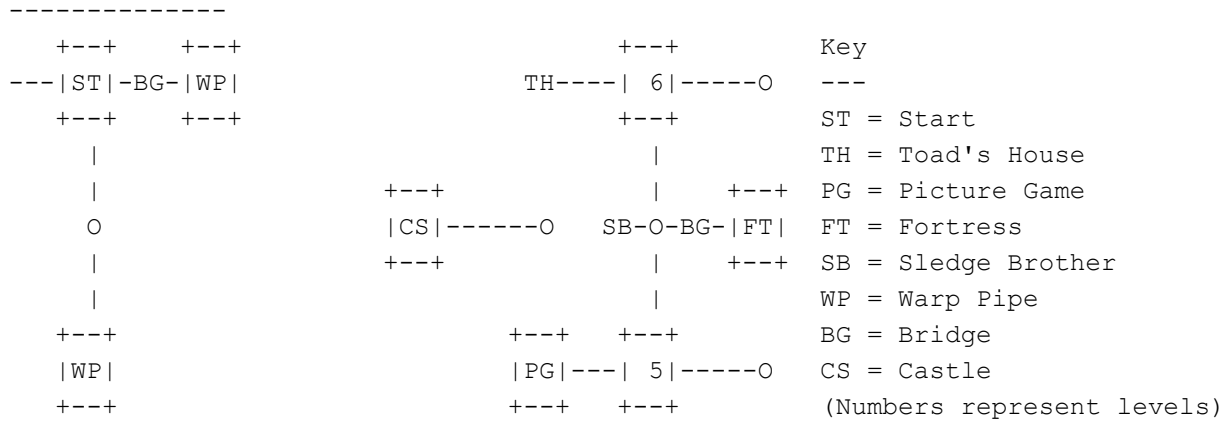

NOTE: A path to the castle appears when you beat the Fortress level.

Map - Part 2/3

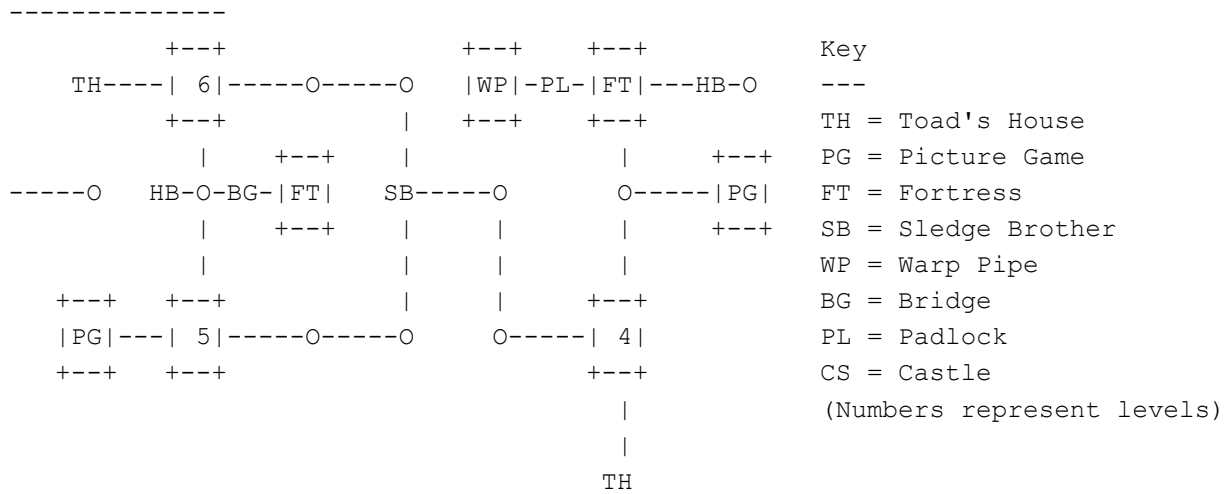

NOTE: The padlock disappears when you beat the first Fortress level.

NOTE: A path to the castle appears when you beat the second Fortress level.

Map - Part 3/3

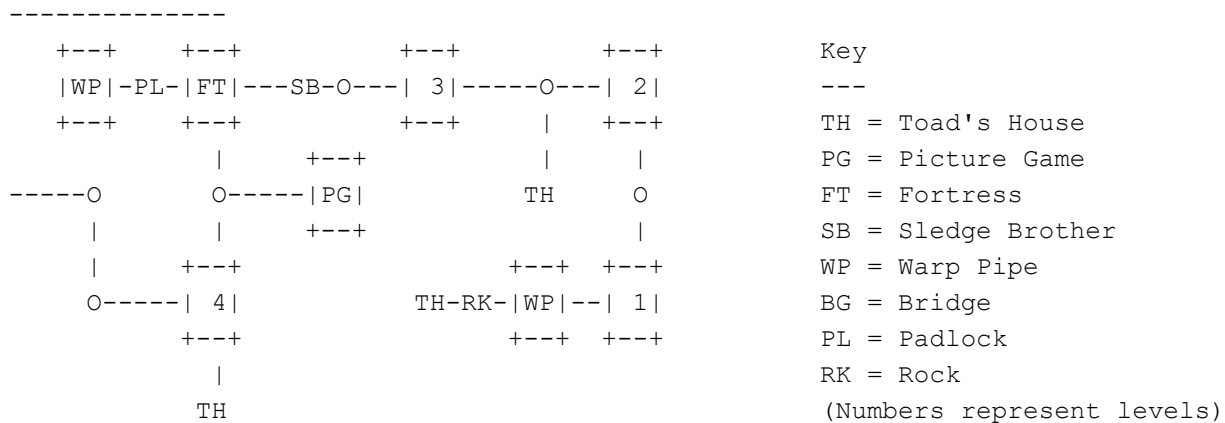

NOTE: The padlock disappears when you beat the Fortress level.

NOTE: The Rock can be taken out using a Hammer.

#### World 4-1

-----

Start by advancing past the two giant pipes straight ahead of you at the start. Watch out for the Piranhacus Giganticus in the second one. You then come to a giant '?' Block, which holds a coin. Then you'll see a brick and wooden block with a Red Giant Koopa Troopa patrolling it. Stomp it and kick it to the right so it smashes the brick underneath the giant '?' Block, which you can now bash to retrieve a Super Mushroom or Super Leaf.

Now cross the gap and onto the normal sized pipe, and get the three coins if you're careful. Move right and you come to a green Colossal Koopa Paratroopa. Avoid it and jump into the waterfall between the four pipes. Swim through it and drop out the other end. You'll see a stack of three bricks. Go past them and stomp the Grand Goomba. In the air you'll see a giant '?' Block above a normal sized brick. Jump onto the brick to reach the block, which holds a Super Leaf Power-up.

Now go through the gap between the four giant bricks and you come to a giant pipe. Jump onto it and from there jump onto the cloud, then jump to the right again onto a cloud platform with a Red Giant Koopa Troopa. Stomp it and kick its shell to the right so it takes out another Red Giant Koopa Troopa on the brick platform - jump onto this and collect the coins. Then jump over onto the giant '?' Block, stomp a third Red Giant Koopa Troopa and kick the shell away. Then jump onto the giant pipe to your right. If you budge the screen enough, you can see a giant pipe with a Venus Fire Trap occasionally popping out. When it's inside, jump over it. If you have a Raccoon Tail, you can glide down safely. Watch out for the Green Gargantua Koopa Troopa on the ground, and enter the pipe.

You emerge at the dark area, so run right and get the card to finish your first giant level!

#### World 4-2

-----

Another flooding level...oh god. Beware of Cheep Cheeps trying to jump up at you as well. Start by jumping onto the green giant pipe to your right, this should keep you out of the water. When the water lowers, jump right onto a second giant pipe and kick the Red Giant Koopa Troopa to the right so it KO's the Red Giant Koopa Troopa on the third pipe. Jump onto there, and onto the fourth pipe when the Piranhacus Giganticus isn't sticking its head out. On the next pipe are some white blocks. Pick one up and kick it to the right and it should bust open the nearby giant '?' Block, and you can get a Super Mushroom or Super Leaf if you are quick enough.

Now you're on a bridged area. Cross the giant pipe that has a Venus Fire Trap in it. At the end of the bridge, make a huge jump to the right to reach the high giant pipe (beware of the Venus Fly Trap in this). Then jump right again and you'll see a huge stack of bricks with a P-Switch next to it. Hit the P-Switch and start getting as many coins as possible, if you collect enough you can visit the White Mushroom House.

To the right in the air above the next pipe is a row of bricks (coins if the P-Switch is still in effect) and a '?' Block, which contains a Starman, so grab it and start advancing right. Over the next pipe with a Piranhacus Giganticus in it, to some more coins and bricks. Several Cheep Cheep will start flying up



now, so be on your toes. Run to the end of the bridge and make a long jump to the right at the end of the row of wooden blocks so you can get on the end platform and enter the pipe.

Run right and grab the card to finish the level.

#### World 4-3

-----

As you run right you will encounter a Sledge Brother. Now beware, as the rumble jump can stun Mario and leave you open for a hammer attack. What I suggest you do is that when he jumps, as he comes down, jump up and stomp him on the head. So after you've taken care of him, go past the two giant bricks and you'll meet another Sledge Brother. You can jump onto the smiling cloud above to perch on him and stomp when he isn't throwing hammers. Enter the vertically standing pipe after the Sledge Brother.

Move right and you'll encounter three Buzzy Beetles (one on the ceiling that drops down and spins towards you), so either kill them or avoid them. Now take a running jump onto the floating platform. Kick away the Buzzy Beetle. In the four '?' Blocks are coins. Now make a running jump to the right (get the coins above the gap if you have a Raccoon Tail) and onto the next high platform. Above you are some wooden blocks with a Buzzy Beetle wandering around on them, so when it drops down and spins towards you, jump over it. Now jump to the right onto the little floating platform and bash the '?' Block above it to get either a Super Mushroom or Super Leaf.

Jump to the right to safe ground. On the ceiling is an Upside-down Spiny, who will drop down and spin towards you in similar fashion as an upside-down Buzzy Beetle. Don't stomp him, though. Take out or avoid the Buzzy Beetle then jump across the gap with the Red Koopa Paratroopa hovering around above it. You'll come to a two-slope sided platform, and above is another upside-down Spiny. When he comes at you, jump over him. Now you have to cross a vast gap to reach safe ground again. It'll be a lot easier if you have a Super Leaf, but if not, try bouncing on the Red Koopa Paratroopa's head to get some airtime so you can get across.

Hop onto the two wooden blocks and above you are three bricks. Bash the very left one for a 1-Up Mushroom and the other two for coins. Quickly follow the Mushroom so you can grab it when it falls off the ledge. Avoid the Spinys and Buzzy Beetles too. Stand on top of the row of five bricks and jump onto the floating triangular platform, then make another jump onto a second triangular platform with two wooden blocks on top of it. Careful when you touch the bottom one, as it can bump you. Cross more gaps while collecting coins if you can. At the very end, enter the upside-down pipe in the ceiling.

You emerge back in the overworld next to the dark area. Run right, collect the card and finish the level.

#### World 4 Fortress (1)

-----

Go right and climb the stairs. Beware of the Hot Foots that jump out of the candles. Drop down at the end and watch out for a horizontally moving Thwomp. Carry right past another Hot Foot, and another Horizontally-moving Thwomp. Jump through the gap it makes when it is against the left wall. There are now two routes you can take here.

#### Route 1

-----



Bills, so avoid them. There are three '?' Blocks between the cannons, which contain coins and a Power-up, which you should get if you need it. Between the second and third cannons are three more '?' Blocks that hold coins. After that, jump the gap and onto the wooden block platform with the cannon on it. From there, jump onto the giant pipe and onto the next wooden block platform.

Now jump across the last gap to a pipe with two cannons to its right. Stand on top of the second cannon and make a long jump to the right onto a third cannon, which is highest of the four cannons in this location. Jump over the pipe (avoid the Piranhacus Giganticus inside it and progress past some more Missile Bill cannons. Stand on the wooden platform three block spaces long, and from there make a jump onto the giant pipe. Now jump over the last cannon and enter the pipe on the ground.

Run right into the dark area, get the card, and finish this tedious level.

#### World 4-6

-----

Go past the green Colossal Koopa Paratroopas, and a brick formation with a Green Gargantua Koopa Troopa inside it. Now cross the gap and get the four coins if you can. Go past the pipe and you'll see a doorway in the platform. Enter it and this will reverse the 'gigantism' effect - all giant enemies will now become regular sized enemies!

Now that all enemies are normal again, continue progressing right. Jump over the small gap and the pipe. Bash the '?' Block for a coin. Go past the Green Koopa Paratroopa and eventually you'll come to a formation of wooden blocks and bricks. Look at the two wooden blocks stacked on top of each other at the left underneath the bricks. If you touch them from the side a Starman will appear, so grab it!

Now progress right and stomp the Goomba and jump in between the two pipes. Against the right-hand pipe are three invisible blocks in the air in a row. Bash them all. The very left one holds a 1-Up Mushroom, so grab it quickly. Cross the next gap to get to some platforms, Red Koopa Troopas, and another giant-normal reverse effect door. Don't enter this one. Instead just carry on heading right.

After the pipe you'll see some floating brick platforms with Red and Green Koopa Troopas on them. Just kill or avoid them, then after that, you get to safe ground next to the dark area, so proceed to run right and finish the level by snagging the card!

#### World 4 Fortress (2)

-----

Start by climbing up the stairway and walking to the edge of the platform. Now jump over onto the platform of falling rings, and now quickly keep jumping across them. Remember, if you stay on too long, you'll plummet into the lava and die, no matter what condition Mario is in. On one ring platform is a Dry Bones, and above it is a '?' Block, which has either a Super Mushroom (which you should get) or a Fire Flower (which you shouldn't bother for if you already are Fiery Mario). Remember to jump around on the platforms to stop them from falling. Then jump across three more falling ring platforms before you reach the safe steel ground.

Go into the tunnel and stomp the Dry Bones. Go right, down the stairway and stomp another Dry Bones. At the end, stomp a third. At the end of the hallway you'll see a block (beware of Dry Bones that fall from the high ledge), which

holds a P-Switch. You can either push this P-Switch to get a secret door for one route, or carry on. Anyway, when you hit the switch, seven white coins appear to the left. They are surrounding an invisible doorway, like so:

000      0 = Coin  
0#0      # = Doorway  
0#0

You've got two optional routes to complete the level from here on.

#### Route 1

-----

Enter the hidden doorway that you've found. You'll now be standing on a large, green pipe, and to your left is a directional platform, which goes in the direction of the arrow printed on its surface. Stand on this one, and it will take you up. Once you are high up, jump onto the wooden block platform to your right. Now you'll come to a '!' Platform. This changes direction whenever you jump on it, as long as you stay on. It will start by moving upwards, then left, up, right, then up again. So jump on it so it takes you up, then jump on it to make it move to the left so you should just be able to stay above the Piranha Plant, and duck beneath the pipe on wooden blocks above.

Now jump onto the next moving platform, which will take you upwards. When it takes you through the gap in the two horizontal pipes, drop off to the right. There are two pipes hanging from the top of the screen here; enter the one on the right. Hit the '?' Block here for a Fire Flower power-up, then return to the previous screen by going back down the pipe again.

Now enter the other of the two pipes. It takes you to a secluded area of pipes. Enter the one to your right that is hanging vertically. Now you'll see another '!' platform to your right. Step on it then jump so it moves to the left. When it's below the gap in the pipes above you, jump on it and it'll move upwards. Beware of the Piranha Plant that sticks out of the pipe on the right. If you are Fiery Mario, pluck him with a fireball. When you're through the pipes, jump on the platform again so it moves to the right. When you're below the gap in the wooden blocks, jump on the platform yet again to make it go upwards, then jump to the left and enter the green warp pipe here.

In this next room are nine coins. Grab them then jump onto the orange pipe. Stand on the left side and jump up to trigger an invisible coin block. Stand on this and jump one block space to the left to get another invisible block. You then have to stand on this, and jump one block space to the left. You won't be able to see Mario, but if you did it right, you should hit a block with a 1-Up Mushroom in it, which falls to the ground. Collect it then go down the orange pipe.

An underground pipe area. Hit the giant '?' Block to cause a tremor and three 1-Up Mushrooms will appear. At the very left end of the ceiling you'll see a brick. If you have a Raccoon Tail, fly up and bash them to enter another secret area and get a lot of coins. Now exit this area via the pipe at the right end side of the room.

You arrive back at the fortress. Scroll down to the end of Route 2 Walkthrough to carry on with walkthrough.

#### Route 2

-----

Get on top of the brick with the P-Switch by either stomping on a Dry Bones

and holding A so you can rise high enough to land on it, or get a good run-up and jump on. If you have the Raccoon Tail, then you can simply fly up to the high ledge. Move right and you'll encounter three more Dry Bones, a pipe, and a Roto-Disc.

Routes join up here

-----  
Get past the Roto-Disc, run to the end of the tunnel and drop down into the battle arena to encounter Boom-Boom. There are three steel platforms around the room to limit your versatility, so stomp him with accuracy, in the usual three stomps formula, or take him out with five fireballs. When you have the all clear, get the crystal, and a bridge to the castle appears on the map!

World 4 Castle

-----  
Oh my. The king has been transformed into a dinosaur!

So anyways, on with the level. You see Mario or Luigi climbing the airship. When you have control, get moving to the right to encounter a flamethrower. Just above and to the right of it are three coins, which you can collect if you want. Past the next flamethrower you can drop down and collect the eight coins and head back up and travel across the long screw on the rolling nut, or you can just cross the deck as long as you keep an eye out for the flamethrowers.

At the end, if you are on the higher deck, move right and get past Rocky Wrench. You can bash the '?' Block for a Super Mushroom/Super Leaf. If you were on the deck, just get past the flamethrowers carefully and then jump up onto the platform with a flamethrower on it. From there, make a long jump onto the platform with a flamethrower on the bottom firing flames downward.

Now either make a massive jump to the right to reach the high platform with a flamethrower on the end, or just drop down, move right, and climb up through the flamethrowers (just don't get roasted alive!). Then enter the silver pipe for another Koopaling encounter, this time with Iggy Koopa. Read the Bosses section of this FAQ for help with this boss.

So Mario returns and is given another letter from the King.

```
+-----+
| Greetings,          |
|                    |
| The thief who stole |
| the Whistle has    |
| escaped to the east |
| side of the Sand   |
| Dunes.             |
| I have enclosed a  |
| jewel that helps   |
|   protect you.     |
|                    |
|                    |
|   Princess         |
|   Toadstool.       |
+-----+
```

The star prize of today is...(drum roll)...a P-Wing!

3.05 - World 5 - Sky Land

Map - Part 1/2

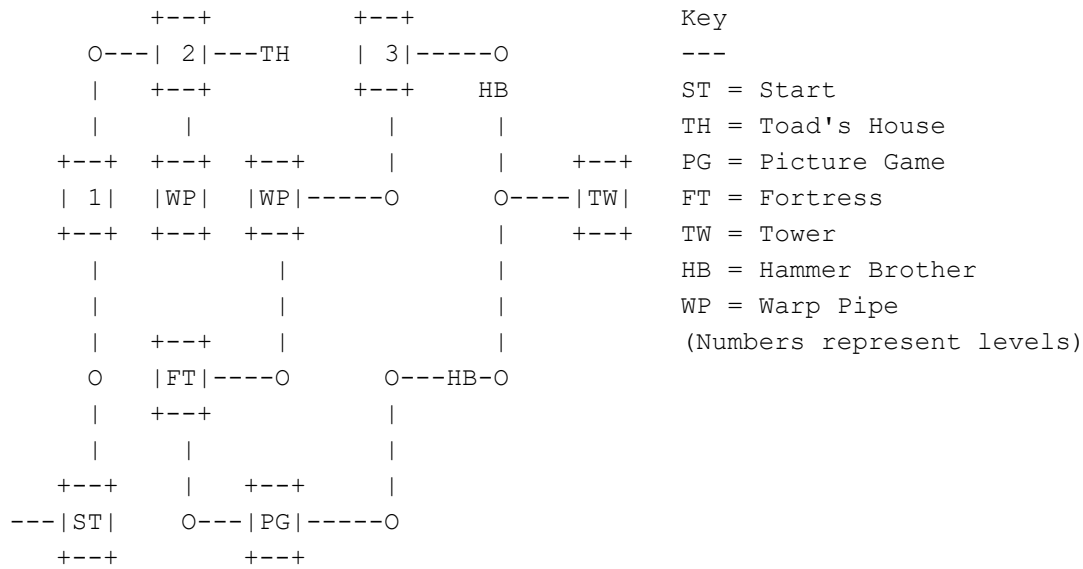

NOTE: A bridge linking the two islands appears when you beat the Fortress level.

Map - Part 2/2

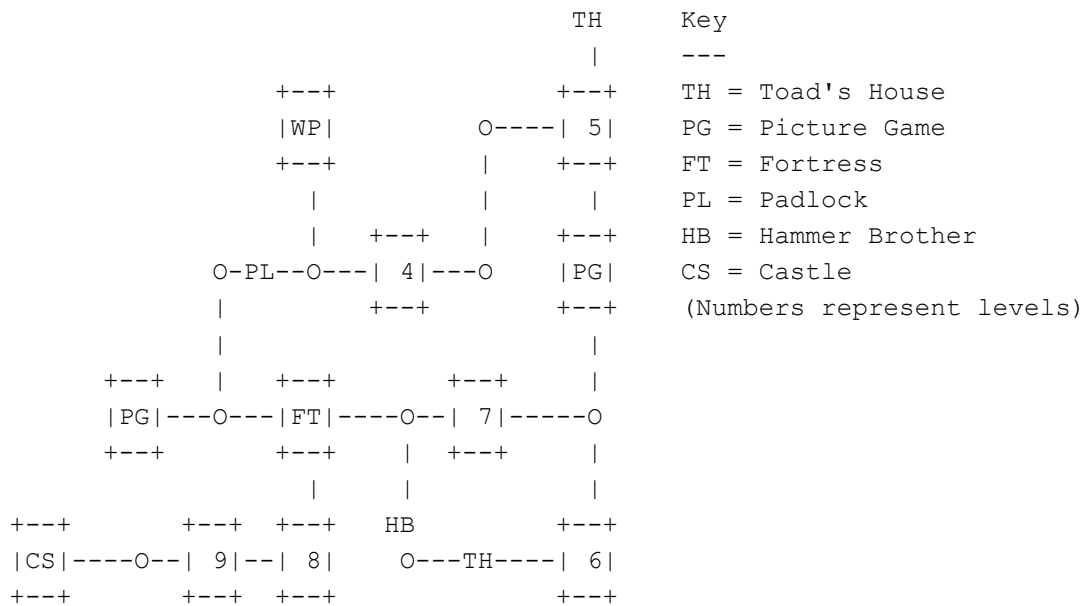

NOTE: The Padlock disappears once you beat the Fortress level.

World 5-1

Jump over Buster Beetle as he charges towards you. Go onto the staircase of bricks. If you touch the wooden block from the side, it will reveal a Super Leaf power-up. Now to the right is a Chain Chomp, so carefully jump onto the steel platform above him. To the right of where you are now is another Chain Chomp. If you can get past him you can bash the '?' Block for a Power-up and escape this area via the brick above it.

Now jump over the pit in the steel structure with the Chain Chomp in it. The

next '?' Block here holds a coin. Now jump on top of the block so you can jump over the Nipper. Head up some more steps, avoid another Nipper, and watch out for another Buster Beetle charging down the stairs. So after the last Nipper you're at the top. Walk over the three bricks and jump over the Chain Chomp. You'll arrive at a row of six '?' Blocks. They contain coins, and the fourth holds a Starman, so as soon as you get it, run right at top speed!

After dropping off the structure, go right and jump over the first Nipper and get the coins. Watch out for the Para-Goomba who makes a landing here. Jump over two more Nippers and a stack of three bricks. Run right into the dark area and get the card, and look out for the Nipper below the card box.

#### World 5-2

-----

Run up the slope and enter the pipe. From here on you have two immediate routes to finish the level.

##### Route 1

-----

This is a lot easier if you have a Raccoon Tail. As you enter this next area, start gliding as you fall. You can reach some brick platforms to start ascending. If you don't, just pray you hit one of the Music Note Blocks to get onto the bricks. At the top is a brick platform that has two Green Koopa Troopas that drop onto it. Dispose of them and enter the vertical pipe.

When you emerge out of the pipe, jump to the top of the slope and slide down it, killing all the Goombas on the way. Climb a second slope and slide down again, taking out more Goombas. Enter the first pipe that you come to.

You enter a room with a giant '?' Block in the centre, encased by a square of bricks. If you are not Super Mario to be able to bash your way in, hit the brick that is sticking out of the left-hand side of the bricks for a Super Mushroom, or a Fire Flower if you are already Super-sized. Bash the giant block to cause a tremor and gain three 1-Up Mushrooms. Then exit by the silver pipe at the bottom-right area of the room.

You re-emerge in the previous area. Head up the slope and you come to four '?' Blocks. Stomp the Koopa Paratroopa twice and pick up its shell and kick it at the block on the ground for a coin. The three blocks in the air contain coins as well. Now run to the end and enter the pipe. Scroll down to the end of Route 2 walkthrough to carry on with walkthrough.

##### Route 2

-----

When you enter the pipe, fall to the bottom while collecting coins, and eventually you will plummet into water. At the bottom of the water are three green pipes. Go down the middle one.

You then fall down a waterfall into another pool of water with a Cheep Cheep. Climb out, and move right. Watch out, as Buster Beetle will pick up the white block and hurl it at you, so jump or duck from the block. When Buster Beetle charges at you, jump over him so he runs into the water. Now go right, pick up the white block, and kick it away. Go past the two upside-down pipes and watch out for Piranha Plants sticking their heads out. Go down the slope and watch out for Buster Beetle, who'll hurl a white block at you, so stomp him. Go past a third upside-down pipe (look out for the Venus Fire Trap inside) and kick away the white block. After the third pipe are three '?' Blocks, which all contain coins. At the top of the slope are two white blocks and

Buster Beetle, so avoid!

Go down the other end of the slope and you'll encounter some more white blocks and Buster Beetles, which you must stay away from. Kill them and move on. Go past two more upside-down pipes and a Buster Beetle in between them, avoid or kill another Buster beetle and enter the pipe at the end of the cave.

Routes join up here

-----  
You'll emerge out of a pipe at the dark area, so you can immediately run right and get the card to finish the level!

World 5-3

-----  
NOTE: This is the only level in which you get to use the Kuribo's Shoe. Enjoy it while you can!

When you start, go down the pipe to the right. Head left, go past the pipe, and you'll see a row of four bricks in the air with a '?' Block in the middle, and a Spiny on the ground. Bash the '?' Block for either a Super Mushroom or a Super Leaf. Now continue moving to the left, jumping over the pipe with a Venus Fire Trap in it. You'll see four bricks between the next two pipes. Wait for the Goomba in the Kuribo Shoe to stand on a brick, then bump it from below so you can get the shoe for yourself!

Head left and DON'T TOUCH ANY of the Spinys. Go left and you'll see some rows of bricks and another Goomba in a Kuribo's Shoe. Some of the bricks hold coins. Proceed to the left, over the next pipe, and you'll encounter Bob-omb. Go past him, jump over the wooden block and go past the Spinys.

The next area has some Munchers on the ground. If you have the Kuribo's shoe on, though, you can safely stand on the Munchers and get the coins, and a 1-Up Mushroom from inside the second brick from the left in the row of five. Jump over three more pipes and go down the pipe at the end.

In the next area you'll see a Goomba in Kuribo's shoe encased in some bricks with white blocks on the side. Just grab the coins above it and move on. Now go over the gaps with the Munchers between, and jump over the Spinys after that. Then jump over another pipe (watch out for the Piranha Plant inside), cross some more gaps with Munchers, another pipe, and you'll see a Bob-omb and three '?' Blocks. Inside they hold (from left to right): a coin, a Super Mushroom/Fire Flower, and a coin.

Stand on the row of bricks and jump onto the pipe when the Piranha Plant isn't sticking out. Start crossing more gaps with Munchers in, jump over another pipe, get the coins, jump over the last pipe and you're on safe ground. Avoid the Spiny and stand on the pipe to jump over so you can reach the three coins in the air. Now enter the pipe.

You arrive at the dark area, so you can run right and get the card to finish off the possibly most fun level of the game.

World 5 Fortress (1)

-----  
Start by crossing the pit. You'll have to simultaneously avoid the Roto-Disc and the Podoboo, it can be annoying at times. Next, get past the Thwomp (let



him drop down first then run past as he moves back up), then you come to four bricks against the ceiling. Break either the second or third brick along if you are Super Mario, you need the other brick to stand on. Jump up and you'll see two bricks and a '?' Block. The block, which is just possible to reach, holds a Super Leaf. Now head back down to the ground.

Now, go past the Roto-Disc, climb the stairs and get past another Roto-Disc. You come to another Thwomp. On either side of him are bricks. Hit the one on the left for a Super Mushroom or Super Leaf. Hit the other for a coin. Now go past the Thwomp and two Roto-Discs above and below you.

Go down the stairs and you'll see a Boo Buddy, and a Roto-Disc to the right. Get past the Roto-Disc, but keep an eye out for the Boo Buddy. Then get past the Thwomp and past another Roto-Disc/Thwomp combination. Then jump the lava pit, and you'll see a small island with a Thwomp above it, surrounded by lava. If you have a Tanooki Suit or Raccoon Tail, this is going to be a lot easier. You need to jump just close enough to Thwomp so he drops down, but you can safely stay on the island to the left. As the Thwomp goes back up, jump onto the little island then quickly make another jump to the right. Climb the staircase and enter the door.

In this next room, run to the end of the hallway and you'll have yet another encounter with yet another Boom-Boom yet once again. For some strange reason they made it simple here. He does not grow wings, run fast, there are no platforms to limit your jumping, and it still takes three stomps or five fireballs to beat him. Oh so simple...

#### World 5 Tower

-----

Head right, past the platform, and past the Roto-Disc. Then jump over the pillar with the Roto-Disc circling it. You'll come to a '?' Block with a Roto-Disc circling it. You can bash this block for a Super Mushroom or Super Leaf. Go past one more Roto-Disc and enter the pipe in the ceiling.

In the next area, go left and past the Thwomp. Keep heading left, jump over another stump in the ground, and get past another Thwomp. Head up the staircase and enter another pipe in the ceiling.

You'll now on the top of the tower. From this battlement, jump over to the right onto the next battlement, and get the coins if you want. Be careful as there is a Pile Driver Micro-Goomba on the edge of this battlement. If you have the Raccoon Tail, swing against the middle brick to reveal a hidden 1-Up Mushroom. Jump onto the next battlement and watch out for the Pile Driver Micro-Goomba. Enter the upside-down pipe hanging from the bricks above.

You arrive back inside the tower. Now move right, and go past the Thwomp and the spike pit (avoid the Roto-Disc, too). Jump over another spike pit and enter the pipe at the end in the ceiling. Head left, up the staircase and enter the next pipe in the ceiling.

You arrive back on the top of the tower. Jump to the right onto the cloud platform and kick away the Koopa. Grab the coins above the bricks and blocks, bash the '?' Blocks for some coins, then bash the brick to reveal a vine. Climb it to the top, drop onto the little cloud platform, jump up onto the next cloud platform and enter the blue pipe. You arrive at a new area in the sky...

#### World 5-4

-----

Immediately from the very start of the game there are two ways to complete the level. If you have a P-Wing, Tanooki Suit or Raccoon Tail, it is best to take Route 1, although both Routes are optional. If you do not have flying ability, then take Route 2.

#### Route 1

-----

On the cloud runway on which you start, get a good run-up and start flying up and right and you'll come to another cloud platform with four pairs of coins on it. Then jump over to the next platform to the right, which has another four pairs of coins. Then from here, take a running jump and fly right and don't stop. You'll eventually reach the very end of the screen and you can fall down to land on the pipe and enter it to emerge next to the dark area. Scroll down to end of Route 2 to carry on with walkthrough.

#### Route 2

-----

Go right to the end of the platform and jump over the spinning platform in the gap to reach a cloud platform. Then make another running jump over the next spinning platform to get to another cloud platform. In the air to the right of you is a platform, which will rotate slowly while you are standing on it. Jump onto this then making a jump onto the platform to your right when it isn't spinning, then jump right once more to a platform that rotates while you're on it, then jump right onto a cloud platform. Now jump over the spinning platform on some wooden blocks. You can swim through the waterfall to reach the other side of it, or jump across. Then jump up onto a second waterfall, which is shorter and a bit easier to get through. Now jump onto another platform, then jump over the Red Koopa Paratroopa and onto the platform. Jump onto the next platform when it isn't spinning, and repeat once more, then jump onto the cloud platform with a pipe at the end, and kill or avoid the Green Koopa Paratroopa. Enter the pipe.

#### Routes join up here

-----

You're at the dark area. Be aware of Lakitu, who'll throw Red Spinys down at you. Go right and get the card to abolish him and finish this cheesy level.

#### World 5-5

-----

The ground here is all made of the falling rings, so you must be active at all times, and try to find any platforms or blocks to keep still if you are getting tired of all the jumping around you may have to do within this level.

You start on a wooden block. Jump right and onto another wooden block and carry on advancing right. Watch out for the Green Koopa Paratroopa at the next wooden block, and whatever you do, DON'T LET THE PARA-GOOMBA DROP MICRO-GOOMBAS ON YOU. If he does, you have to stay in one place as you shake them off and plummet to your death, and you cannot jump well. So avoid at all costs. After the next wooden block and a Green Koopa Paratroopa, you'll see three wooden blocks stacked up together and the falling ring bridge is raised a bit. To the right is a pipe with two bricks on it that you can smash if you have the Raccoon Tail, although you can't enter this pipe. However, you can get into the next one.

You fall down while grabbing coins into an area with a giant '?' Block, which you can bash for a Tanooki Suit! Once you have it, exit by the pipe at the right end of the ceiling. Scroll down to the \*\*\* if you took this.

Carry on and you'll see four '?' Blocks below a pipe with a Venus Fire Trap in it. The first one holds a Super Leaf, while the others have coins. Moving on, jump over another pipe (watch out for the Venus Fire Trap inside it) and you'll come to another raised part of the falling rings. Underneath are coins, which you can grab if you fall on a ring and jump up in time, but it's risky and I wouldn't recommend it. Just head right and look out for a Para-Goomba dropping Micro-Goombas and a Fire Chomp. Then, jump over onto the pipe when the Venus Fire Trap isn't sticking its head out and jump to the other side.

\*\*\* To the right you should see a formation of wooden blocks with three bricks in the middle. Quickly bash out the bricks from below if you are Super Mario. The brick on the left has a coin in it, and the brick on the right has a Super Leaf Power-up. After that, kill or avoid another Green Koopa Paratroopa and run to the end of the falling ring bridge to safe ground. Proceed to run right and grab the card!

#### World 5-6

-----

A side-scroller level. We haven't seen one of those in a while. So...uh, anyway, hop onto the stack of four wooden blocks at the start. You'll see some flying Beetles coming towards you. Use these to stay airborne, but jump carefully. When you land on one, it will drop down for a second, then begin to fly back up again. It's easier if you have a Raccoon Tail.

From the start you should get some coins and keep jumping on the beetles and go in according heights you'd like. Soon you'll see a low '?' Block above a cloud, but don't bother going for it, it's too much bother. Avoid the Koopa Paratroopa and use the Music Note Block to bounce up to the wooden blocks. You can get some coins here that are arranged in zigzags. You'll then have to cross a gap and use a Music Note block to keep up, so be very careful.

After that is a brick platform and you'll have to start moving across on the brick platforms while avoiding a Fire Chomp. Very difficult. After that you'll arrive at a pipe below some bricks, so quickly enter it before the Fire Chomp explodes.

Quickly run right and grab the card before Lakitu takes you out. Oh, and by the way, I VERY strongly suggest you skip this level. It'll make your life a lot easier.

#### World 5-7

-----

Head right and jump over the pillars of bricks and you'll see some bricks in the clouds with some '?' Blocks above them. Bash these for coins, and a Fire Flower in the wooden block on the top of the brick stack that you can touch from the side. There are three more '?' Blocks with coins. Now climb the brick wall and watch out for Pile Driver Micro-Goombas on top. Now drop down the gap between the wooden blocks after this, onto the pipe (but watch out for the Venus Fire Trap inside it). You can bash the '?' Blocks on each side for coins. Now climb out again and continue heading right, but watch out for more Pile Drive Micro-Goombas in the bricks. When you drop down, you can bash the brick sticking out of the side for a coin and proceed to head right. Lakitu will appear here, so it's time to kick the gears up.

After the gap and above the pipe is a brick. Stand on this and stomp Lakitu so he won't be of bother. Continue moving right and jump over the cannons and watch out for the Pile Driver Micro-Goombas. Drop off the edge and run right

across the cloud and into the pipe at the end. Lakitu will be waiting for you on the other side, so quickly run right and snatch the card to finish the level off.

#### World 5 Fortress (2)

-----  
From the steel platform you are on, make a careful jump onto the steel block to the right (look out for lava and Podoboos). Then jump onto the pipe and enter it.

You land on a secluded area of a bridge. Cross the gap (avoid the Podoboo) onto the next part of the bridge, then cross another, wider gap, onto a smaller part of the bridge. Two Podoboos jump out of the lava here, and one goes higher than the other, so jump with caution. At this next part you'll see Podoboos jumping out of the ceiling, so you have to be even more careful now. On the next part of the bridge are '?' Blocks. Watch out for the Dry Bones, though. One of the blocks has a Starman, so be quick and grab it! There is a Boo Buddy next, so avoid this, and cross the gaps on the tiny parts of the bridge.

Then, above the long stretch of bridge are two '?' Blocks, which hold a Super Mushroom/Super Leaf and a coin. Then jump onto the next bridge and make your way across it but look out for Podoboos that jump out and a Boo Buddy. After the Dry Bones, enter the pipe in the ceiling.

Jump over the gap and run to the end of the hallway. Simple again, like the last Boom-Boom. But this time he grows wings after a stomp and loses them. It's still simple, though, just three simple stomps to take him out and finish the level when you grab the crystal that he drops to open the padlock on the map.

#### World 5-8

-----  
No, what, Lakitu again?! Best to keep on your toes for this level. Start by making a running jump onto the higher cloud platform to your right. The four '?' Blocks contain coins and a Super Leaf Power-up. After that, start crossing platforms. There some Koopas on some of them, and you must be quick. Start climbing the clouds upwards and watch your footing. Enter the pipe at the end of the high cloud platform to emerge at the dark area. Lakitu is waiting at this end, so quickly run right and get the card to finish the level.

#### World 5-9

-----  
Oh no, a scrolling screen level. Start by jumping over the Red Koopa Paratroopa onto the higher cloud platform then onto the wooden platform. Carry on jumping across the wooden platforms as they arrive to your right. On the eighth platform a Fire Chomp will arrive to attack you, so it is best to take him out with a stomp to prevent him exploding and knocking you out. Another will appear, so you have to kill him as well. When the last platform takes you to the cloud platform, enter the upside-down pipe. You emerge at the dark area with Lakitu waiting yet again, so run right and snag the card.

#### World 5 Castle

-----  
This time the King has been transformed into a bird, so press A and view the cut-scene of Mario or Luigi climbing the airship's anchor. When you have control over Mario/Luigi again, start moving right, and avoid the cannon and flamethrower and jump over them. The '?' Block next to the crate holds a Super



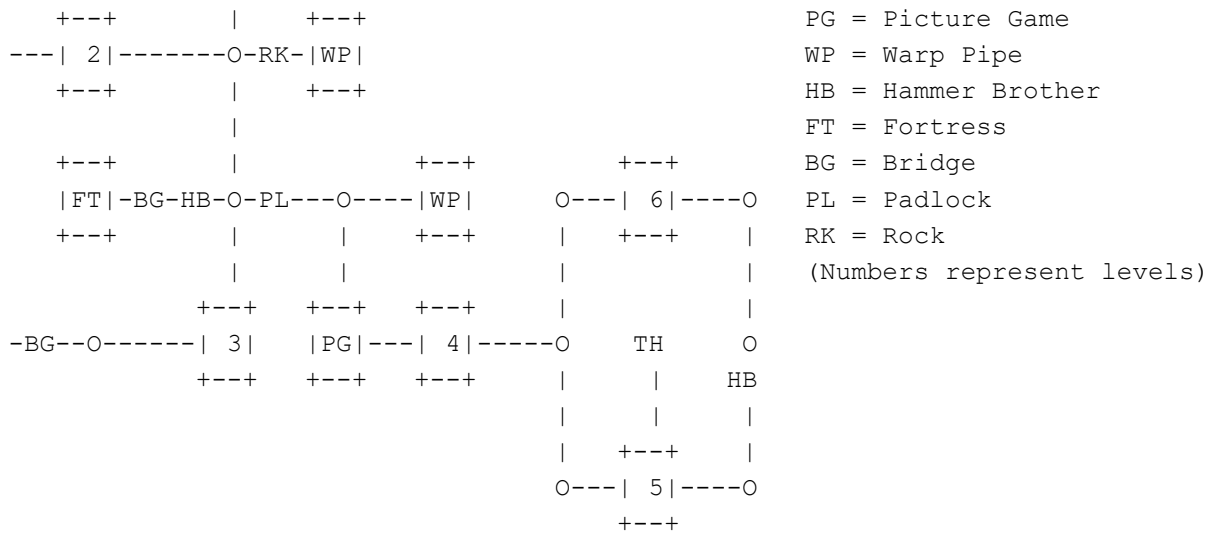

PG = Picture Game  
 WP = Warp Pipe  
 HB = Hammer Brother  
 FT = Fortress  
 BG = Bridge  
 PL = Padlock  
 RK = Rock  
 (Numbers represent levels)

NOTE: The Padlock disappears once you beat the Fortress level.  
 NOTE: The Rock can be taken out using a Hammer.

Map - Part 3/5

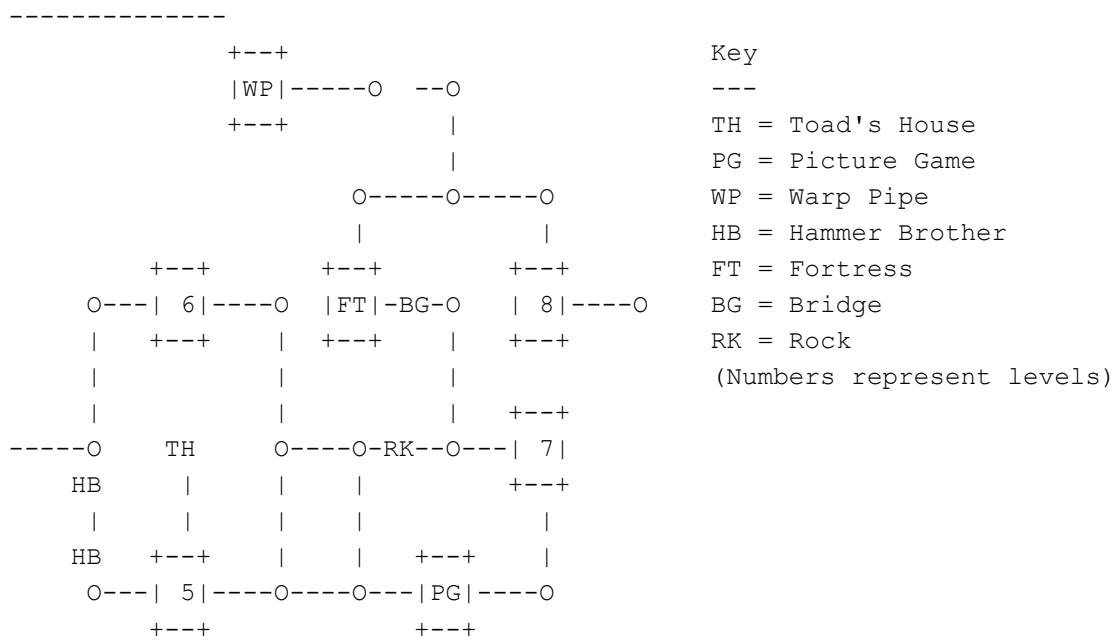

Key  
 ---  
 TH = Toad's House  
 PG = Picture Game  
 WP = Warp Pipe  
 HB = Hammer Brother  
 FT = Fortress  
 BG = Bridge  
 RK = Rock  
 (Numbers represent levels)

NOTE: A path to the Warp Pipe appears after you beat the Fortress level.

Map - Part 4/5

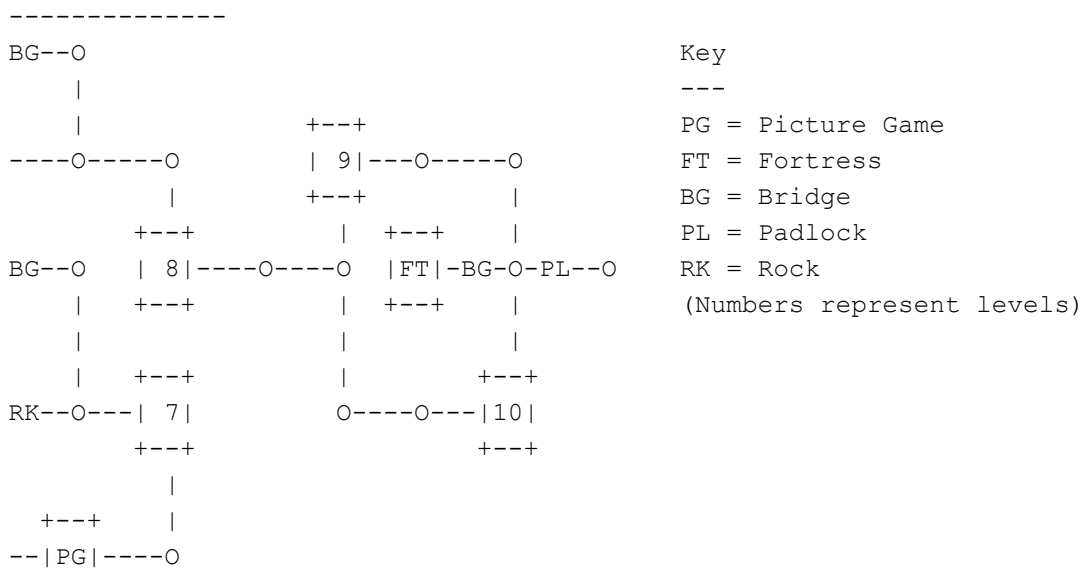

Key  
 ---  
 PG = Picture Game  
 FT = Fortress  
 BG = Bridge  
 PL = Padlock  
 RK = Rock  
 (Numbers represent levels)

+++

## Map - Part 5/5

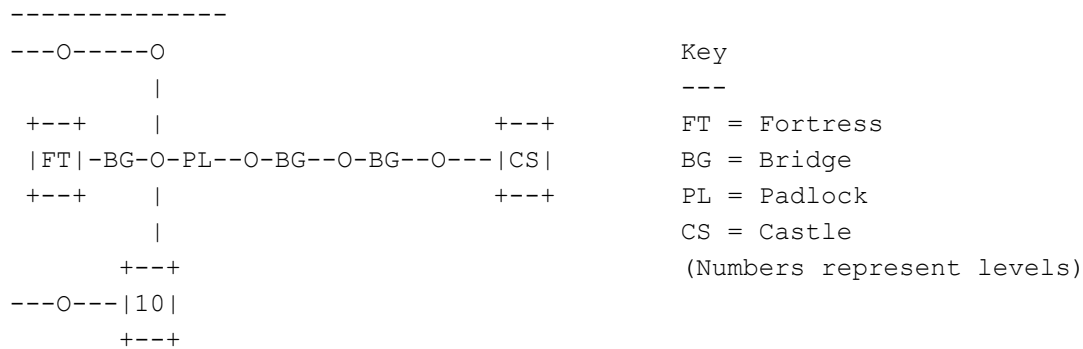

## World 6-1

-----  
Jump onto the ice platform and jump onto the one onto the right. There are two bricks and a '?' Block above you, which contains a Fire Flower. This can be helpful, but remember, if you use it against enemies trapped in ice, they come to life. Anyway, there's a Ptooie in the pipe to your right. Take him out with the Fire Flower if you got it or jump through the gap between him and the spiked ball when he blows it high up. Then after are three coins and a walking Ptooie, who you should take out with fire or avoiding by jumping through him and the spiked ball when he blows it really high. Jump over the next pipe which has a Piranha Plant in, and the '?' Block you come to has a coin in it. Jump over the small pit and get the three coins. Jump over the next small pit and go over the pipe when the Venus Fire Trap isn't sticking out.

Go past the two Ptooies after this, and bash the '?' Block for a coin. Jump over the pipe and bash the '?' Block for a Super Leaf. Jump onto the next ice platform for three coins and watch out for the spiked ball being blown up by the Ptooie, it is possible to hit you. Keep jumping platforms and you'll go past a Red Goomba and another walking Ptooie on the ground. In the pipe at the end of the platform is a Ptooie. If you've got Fire Power fry him or jump through when the spiked ball is high. After one last gap to jump you can run right into the dark area and get the card.

## World 6-2

-----  
Another scrolling-screen level. You start on a platform of wooden blocks. Jump right onto the next wooden block platform, and make a jump over onto the higher of the two cloud platforms moving to the left, then onto the ice platform and get the coins. Jump onto the cloud platform approaching then down onto the ice platform down near the bottom with the white block and '?' Block on it. Kick the white block against the '?' Block for a Super Mushroom or Super Leaf.

To the right is a wooden platform with a pile of bricks on it. Climb over them using the clouds that float through it or bash them with a Raccoon Tail if you have one. Then jump onto the ice platform (best to leave alone the Red Koopa Troopa), get the three coins in the air, onto the next ice platform with some bricks on it, get some more coins in the air, then onto the wooden platform, jump over the pile of bricks, jump onto the next wooden platform and get the coins if you're careful enough.

Now you'll see some more clouds approaching before a huge wooden block pillar. The screen starts to move upwards so you have to stay on the clouds and if you fall through the bottom of the screen...you guessed it...you die! At the top of

the wooden pillar, make a jump onto the ice platform then the wooden platform to the right of it two white blocks and a brick on it. If you kick away the white blocks quickly enough you can start hitting the brick, which is actually a multi-coin block. Jump onto the next wooden platform after this and kick away or avoid the Red Koopa Troopa.

Jump onto one of the cloud platforms and the screen will start moving back down again. There's an ice platform to jump onto, then a wooden block platform with three coins above it. Use the cloud platform to reach the next wooden platform and carry on jumping across until you reach a green pipe. Enter it.

You arrive next to some water at some white hills (must be the snow). Run right and get the card in the dark area to finish off this annoying level.

#### World 6-3

-----  
Run right and jump onto the Music Note Blocks and bounce high. Hug the ice wall to your right and you should land on a moving wooden platform. It's easier if you've got a Super Leaf. When it takes you under the ice wall, if you are Super Mario, duck so you can squeeze under. Now jump up onto the ice platform with the Red Koopa Troopa on it, stomp and kick the shell to the right and see if it can hit the '?' Block to the right for a Power-up. Run or jump across the little ice pillars and then watch out for the Red Koopa Troopa on the huge ice blocks, you may collide if you do not stop quickly.

Jump onto the 'L' shaped row of ice and kick away a second Red Koopa Troopa. Then, to your right, you should see some bricks. Cross them and you'll arrive on a platform of ice. Then, make a running jump onto the next little ice platform, then again onto another one with a brick above it; this is a multi-coin block.

Then, carefully drop down onto the ice block, jump over onto the next small platform of ice, then over to the right you should see a stack of ice with a wooden platform moving to and fro underneath it. Jump onto this wooden platform and carefully jump over the stack of ice and then onto the top of the 'J' shaped ice platform. Using the brick as a stepping-stone, jump onto the next stack of ice and get the coins if you want. Then drop down onto the moving wooden platform. You then have to jump over the two Red Koopa Paratroopas or bounce on them to get a lot of air, cross the large gap and run right into the dark area to get another card.

#### World 6 Fortress (1)

-----  
When you start, drop down through the steel and jump onto the blue blocks on the wire and it'll start carrying you across. Podoboos will jump up from the lava to attack, so beware. If you can, bash the '?' Block on the way up for a Power-up. It'll then take you through a narrow tunnel with spikes on the bottom, so stay still. It'll then take you down through an area full of Roto-Discs that come into contact with you if you stay on the platform, so jump when it's about to touch you. After the third Roto-Disc, go into the alcove on the right and enter the doorway.

In the next room, to the right is a steel pillar with two Roto-Discs simultaneously going around it. Carefully get past it and bash the '?' Block just to the right of it for a Power-up. The you come to another two Roto-Discs. Between them are five '?' Blocks. In the very left one is a Starman, and in the other four are coins. It'll bounce around a lot though, so when you try to catch it, stay away from the Roto-Discs!



Climb the little staircase and jump over the spikes onto a steel platform with a '?' Block above it with a Roto-Disc going around it. Bash the block for a Power-up, then jump over the other side of the Spike pit and enter the doorway. In this next hallway, run into the open to have yet another encounter with Boom-Boom. There's two steel blocks in the room but they'll hardly be of bother. When you stomp Boom-Boom, he'll grow wings but he's still easy to topple with another couple of stomps or with 5 fireballs so he vanishes and leaves the crystal behind for you to get, unlock the padlock on the map and carry on with this world.

#### World 6-4

-----

Above you when you start are three coins resting on falling rings, which you can reach if you have a P-Wing equipped, or if you make jump from the iced platform to the right and glide over with a Raccoon Tail. Anyway, get the coins or not, cross the first gap onto the platform with a small icy hill on it, then to the right is a spinning platform. When it has stopped spinning, jump onto it then onto the giant ice block after it. Then jump onto the small pair of ice blocks with a wooden block on top of it. To the right are some icy stairs with Goombas going down them; once all the Goombas have gone down, jump over. At the bottom of the stairs you can see a brick, which holds a 1-Up Mushroom but it's a bit risky to go for as you may slide off the ice block beneath it.

Anyway, get the Mushroom or not, climb onto the ice platform above the stairs and jump onto the top of the large ice block wall. Afterwards you'll see a wooden platform on a wire. Step on it and it will start moving. Quickly jump onto the top of the two giant ice blocks and wait for the wooden platform to come out from under the ice. When it goes, jump back onto it and it will take you to a spiral in the wire. To the right of the top of the spiral is a '?' Block, which contains a Super Leaf Power-up. You can get some coins along the spiral.

After that, you'll see a horizontally moving platform at the bottom of the screen. Jump onto this, then onto the two wooden blocks to the right of it. To the right of these is a platform moving along a slanted rectangle wire. Jump onto it, then another one to the right and when this one is at the top of the wire, jump onto the top of the giant ice blocks, then hit the P-Switch on top of the high stack of bricks to turn them all into coins. Quickly jump onto the long platform of giant ice blocks and start running right, going past the spinning platforms, collecting coins, jumping gaps and ducking under some ice blocks. At the end you'll see a non-stop spinning platform on the edge of the platform underneath a giant ice block. Jump through the gap and over the pit and run right, into the dark area, and get the card to finish the level.

#### World 6-5

-----

NOTE: This is a very unorthodox level. You need to have a Raccoon Tail in order to be able to reach the exit, and at the 'end' of the cave is a pipe, which leads to a small area with a Super Mushroom/Super Leaf Power-up. You can use this as well as another block in the cave to get Raccoon status. This walkthrough will refer to what to do if you are Raccoon Mario. If not, go to the end of the cave to retrieve the power-ups so you can therefore complete the level.

Climb over the giant ice block staircase and enter the green horizontal pipe in the ice wall. You arrive underground, and you should see some Buster Beetles run off to the right. Follow them and run past a pipe hanging from the ceiling

and you'll come to some white blocks. Watch out for Buster Beetles throwing these, stand near them and duck so they just fly over you and stomp the Buster Beetles when they are out of ammunition. Above these white blocks is a '?' Block that holds a Super Leaf Power-up, which helps you to get Raccoon status if you need it.

So after this, run up the slope and watch out for two Buster Beetles near some white blocks; take them out if you find it necessary. Now you come to a stack of white bricks and a Green Koopa Troopa to the right. Whatever you do, don't touch the Koopa...yet. Go past him and look out for the white block that the Buster Beetle throws. Dodge it and stomp the Buster Beetle.

Now here's where being Raccoon-Tailed Mario comes in. Stomp the Green Koopa Troopa in this area and make a run to fill up the P-Meter and pick up the shell while doing so, then fly up through the gap in the ceiling that is between the stack of three white blocks to your left, and the four bricks on your right. Once you're up at the top of this area, kick the shell to the right into the gap between the bricks with the Nippers in. It'll kill the Nippers and the bricks, giving you room to enter the pipe to your right.

Remember, if you aren't Raccoon Mario, you can always go back and get another leaf. Anyway, once you're out of the pipe, run right into the dark and get the card to finish this level off!

World 6-6

-----

Another level in which we start by entering a pipe. So, do that now.

When you emerge in the cave, head right and climb onto the platform by using the wooden blocks. Jump over the Spike, and watch out for the spiked ball that he'll throw. Head up the slope and get the coins. In this next part, you'll have to watch out, as a Cheep-Cheep will repeatedly jump from one pool to another, and you don't want to be involved in that equation. At the end, stomp the Spike in the pit and bash the '?' Block for a Super Mushroom or Fire Flower if you need it.

Now, go back down to where you started, and now take the bottom route. After going down the stairs you'll see another of those series of pools with a Cheep-Cheep jumping around in each pool. As you cross the pools, you'll see an upside-down pipe that has a Piranha Plant popping out of it every so often. You'll have to be careful to get by here; use your Fire Power if you still have it to take out the Cheep-Cheep for less annoyance.

After getting past that, kill or avoid another Spike and jump onto the top of the slope to the right. Go down the slope and jump over the pipe at the bottom (watch out for the Venus Fire Trap inside it). Go back up the other side of the slope and past another pipe in the ceiling, which also has a Venus Fire Trap in it, then enter the water after it.

Swim through the tunnel and watch out for the Cheep Cheep in it. Wait until it swims off to the right before you can go into the open. There are several more Cheep Cheep here, so do your best to avoid them. Swim right and past a rectangular platform then head to the surface of the water. Here you'll see some wooden blocks and two '?' Blocks crammed between them, which contain a coin, and a Super Mushroom or Fire Flower, which is good for fending off the Cheep Cheeps.

Swim to the bottom of this block structure to see another structure of wooden blocks shaped like a 'L'. Swim right past this and keep going right, past some

more wooden blocks and Cheep Cheeps, and four pipes with Piranha Plants sticking their heads out of them. Also watch out for another Cheep Cheep while swimming through the pipes. If you have fire power it'll be a lot easier. After that, climb out the water.

Drop down into the narrow tunnel. When you head right, you'll have to deal with three Spikes, and with no room to jump, it's going to be a toughie. However, if you still have the Fire Flower, it'll be easy. After that there's a pipe in the ground with a Venus Fire Trap. Get past that and you come to some more little pools with a Cheep Cheep jumping around them. When you get past those there's a Spike to take care of before entering the pipe at the end of the cave.

Once you emerge, jump over or kill the Spike and continue to run right to get the card and finish the level.

#### World 6-7

-----

Oh god...another screen scroller. Start by jumping off your starting platform onto the platform of falling rings. Jump right, over onto a next one, then onto the ground. Bash the '?' Block for a Super Leaf, which can prove very essential. To the right of the platform holding this block is a falling ring. Stand on this so you can access the next area of the stage. Watch out for the Fire Chomp in this area.

Jump onto the platform of four falling rings and try to kill the Fire Chomp if you can, then jump right and down onto the ice platform. Jump onto the next ice platform to your right and get some of the coins in the air. Then make a jump to the right onto another platform of falling rings, then another platform, which has a '?' Block above it, containing a coin. Carry on moving to the right and jumping across the falling ring platforms. Remember, it's essential to get as many coins as possible to access the White Mushroom House.

Anyway, after a big set of those falling ring platforms is an ice platform near the bottom of the screen, and above it are two bricks and a '?' Block. This holds a Fire Flower, but I for one, don't recommend it. The Super Leaf is far better for completing this level with. After that, climb on top of the 'J'-shaped array of ice then hop onto one of the two falling rings. When it falls jump right onto the platform of three falling rings against the two ice blocks.

As you move along the falling ring platforms, the screen will start to go up. Climb up with the screen and at the top is a green mushroom platform, and a nearby Fire Chomp, who you should stomp straight away. After two sole falling rings in the air, jump onto the high ice platform and step on the falling ring. When it falls jump right onto the Music Note Blocks so you can safely enter the pipe.

You fall down onto a cage of iced coins with a Koopa Paratroopa hopping around inside it. You can melt the ice if you have a Fire Flower equipped. If not then just proceed to run right into the dark area and get the card to finish off the level.

#### World 6 Fortress (2)

-----

NOTE: This entire fortress is made of ice. Be careful on the slippery floors, especially when you are facing Boom-Boom at the end. It is recommended you use a Super Leaf during this level.

Head right and climb onto the ice platform. Above you is a Boo Buddy, so keep

an eye on him. Move right as quickly as you can and drop down the gap before the frozen horizontally moving Thwomp gets a chance to hit you. Go right and at the end of the ledge above you is a '?' Block that holds a Super Mushroom if you are Regular Mario, or a Super Leaf if you are in any other state of Mario. This leaf will come in handy, so try your best not to lose it.

When you stand on the ice platform to the right of the block, the Thwomp above you will be triggered. When he just goes past you on his way back to the left, immediately jump up through the gap, run right and jump over the ice stump so you are safe. Run right through the tunnel and you'll come to some more drops. When you stand above the Thwomp he'll also be triggered, so as he moves back across, when he goes past you, drop down to the floor to carry on.

Run right, and then you'll see a pile of six giant ice blocks, and a Thwomp at the top of the room. Get near enough to make him move and as he retreats back to his original resting position, quickly jump on top of the giant blocks, run right and duck so you slide under the two ice blocks sticking under the ceiling, drop off the edge of the giant blocks and jump over the gap.

This next platform has two Roto-Discs, so be careful to avoid them. Bash the '?' Block above to get a Super Leaf if you didn't already have one, and continue moving on right. The Thwomp will be triggered, so you can quickly get through the gap and jump over the stump, but watch out for the two Roto-Discs, and the Boo Buddy below. Carry on right, and at the end of the platform, below is another Thwomp. Trigger it off, and before it starts moving back, quickly drop through the narrow gap and onto the ground. Run right and look out for a horizontally moving Thwomp at the end of the tunnel. Jump onto the ledge of giant ice blocks and enter the doorway. Now run to the end of this next room for another encounter with Boom-Boom.

There are a few obstacles to overcome here. First of all, there are a couple of ice blocks in the room and a platform against the right wall to limit your jumping. Boom-Boom starts on this platform. He doesn't fly here, but after one stomp he makes some very high and quick jumps, and after a second stomp he'll start moving from side to side very quickly, so it is best to perch on him from the platform. The usual three stomps or five fireballs will do the trick, and you can get the crystal to create a bridge across the lake on the map screen and finish the level off.

World 6-8

-----

For some strange reason or another, it's become grass land in this level. Oh well, there must be at least ONE warm spot in the ice land. Anyway, when you start, to your right you'll see a pile of five white blocks, and on top of the hill is a '?' Block. Pick up a white block and kick it against the '?' Block to retrieve a Super Leaf Power-up. Now just below and to the right is a pipe with a Ptooie sticking out. When the spiked ball it is blowing is low, jump over and onto the grass. Go past the Green Koopa Troopa in the small pit, and continue advancing right.

In this next little pit are some Nippers, so jump over them and make sure they don't bite you. Jump over a standstill Nipper, go right and jump over two moving Nipper Plants. After them get past three Spikes and a Buster Beetle. Slide down the slope and you'll come to a '?' Block encased in white blocks. You can use the white blocks to take out any enemies if you approach you, and to bust open the '?' Block for a Super Leaf Power-up.

Then, you come to four white blocks. Watch out for the Buster Beetle nearby that'll throw them at you. Take him out and keep moving right to a stack of



into coins, there's a small gap with a Music Note Block above it. Jump over that and over the wooden block platform. There is a pipe here with a Piranha Plant that occasionally pops out, so go past it. Then, to the right of that is a narrow gap and a pipe in the ceiling above another pipe that has a Venus Fire Trap in it. Try to kill the Venus Fire Trap if you can. If not, wait until it goes back into the pipe and jump on top, then enter the pipe in the ceiling.

Back in the overworld, run right and jump over the giant ice block and continue running right into the dark area to get the card and finish off the level.

#### World 6-10

-----

Start by jumping the gap onto the next platform of big ice blocks. On the ice platforms above you are Red Koopa Troopas; so deal with them or just ignore them, then cross onto the next giant ice block platform then jump over another gap so you arrive on a platform with pipes on each side. Ignore the pipes; to the right you'll see a platform of six bricks and a '?' Block. Bash this block for a Fire Flower Power-up. Kill or avoid the Red Koopa Troopas on here too.

On the next part of the ground you'll see a big wall of bricks being supported at the bottom by six white blocks, and to the left are two white blocks and two bricks. Buster Beetle will start picking up the white blocks in the wall and making his way through. When he gets through, greet him with a fireball or kicked white block and then slide-duck under the wall.

In the next part of the level you'll see some more white blocks on the ground and three '?' Blocks. To the right are some extra white blocks and a Buster Beetle that throws them around. Kill this Buster Beetle and start raking your rewards out of the three '?' Blocks; two coins and a Super Mushroom/Fire Flower. Now to the right you'll see some frozen coins and frozen Munchers. Use fireballs on the frozen coins to thaw them and collect them, but not on the Munchers or they'll come to life! Now, jump over the pipe and kill the red Para-Goomba. Next are nine frozen coins arranged in a big squared formation. Thaw them and collect the coins.

Now hop onto the platform with frozen Munchers (careful not to thaw them). To the right is a big gap that you have to cross. If you've got the Super Leaf it'll be a doddle; if not, stomp the Red Koopa Paratroopa's head and hold the jump button to bounce high and get some airtime so you can finish the gap.

Next you'll be on a long platform of frozen coins and Munchers. You'll see some white blocks and a nearby Buster Beetle, so when he throws them, take him out and continue to advance right. As you move ahead you'll come to more white blocks and Buster Beetles; but just repeat the process. Then, at the end of the platform, you need to make a massive jump over onto a pillar of giant ice cubes, then jump onto the rotating platform when it is stationary then jump onto the next pillar of giant ice cubes (careful of the Red Koopa Troopa).

Carry on jumping over the giant ice cube pillars and when you get to safe ground, advance to run right and into the dark area so you can collect the card and finish off the level.

#### World 6 Fortress (3)

-----

The ceiling above you is spiked from the start. Run right, and jump onto the pillar with the two Roto-Discs circling around it, then jump over the spikes and onto the conveyor belt, before jumping over the rest of the pit and onto another pillar with Roto-Discs going around. There is a Boo Buddy here also, so

keep an eye on it at all times.

Jump over the next pit of spikes onto yet another conveyor belt. There's another Boo Buddy up above, so watch out for that also. At the end of the belt, make a jump onto the steel pillar. There's a Stretch on the ground, so beware of that. Above the end of the Stretch is a '?' Block. If you're daring, you can step on the Stretch and bash this block for either a Super Mushroom or Super Leaf. Then, cross another Stretch and jump over another steel pillar (watch out for a Boo Buddy nearby). Then, after going past yet another Stretch there's another pillar with a Roto-Disc circling it.

Jump onto this, and head right and get past the Thwomp. Then make a jump onto another conveyor belt to your right, which has a Roto-Disc going around the middle of it. Finish running across this conveyor belt and drop off onto the ground. Now carry on going over two Stretches with two Roto-Discs circling around in opposite directions in the gap in the middle of the Stretches. At the end of the second Stretch, make a long jump over the rest of the spikes and enter the doorway.

You fall into a room. Don't move while you fall. You'll land between a group of three Boo Buddies. The floor will start to move upwards. When it finishes moving, enter the doorway on the right hand side of the screen. Run right to the end of this hallway for another encounter with Boom-Boom. This fight is a rather tricky one. There are five steel blocks scattered around the room in some sort of zigzag pattern, which can affect your jumping. Boom-Boom attacks in the same method as he did in the second fortress, so be very careful with your timing. Three stomps is the usual to take him out so you can get the crystal and unlock the path to the castle on the map.

#### World 6 Castle

-----  
The king has now been transformed into a seal, and you've got to get the wand back. Yeah, we've heard that one five times before now. Anyway, you see the ship climbing scene, then you have control over the Mario Brother you are playing as.

Go right, across the deck and you come to one of those long screws with bolts. Carefully jump repeatedly on the bolt to move across and be careful not to fall! When you're safely across jump onto the other side of the deck. Climb the steps and below you'll see two screws and bolts. On the top one, keep moving right until near the end, then jump onto the second screw and jump repeatedly on that to move right, until you can reach safe ground.

Now start going down through the steps and watch out for the flamethrowers. Cross a gap and go through three more flamethrowers. Then, climb up at the end and the screen starts to move up. To the left you'll see two '?' Blocks, they hold a Super Mushroom/Super Leaf in the left one, and a coin in the right one. Then, the ship will start moving to the right. Take the lower route and climb up and jump over the pillar and climb into the warp pipe. For help with the boss here, Lemmy Koopa, please take a look at the Bosses section of this FAQ.

```
+-----+
| Greetings,          |
|                    |
| I am well. Please  |
| retrieve the Magic  |
| Whistle hidden in  |
| the darkness at the |
| end of the third   |
```

```

| world. |
| I have enclosed a |
| jewel that helps |
| protect you. |
| |
| |
| Princess |
| Toadstool. |
+-----+

```

Reward number 6 from the princess is...a P-Wing!

```

=====
3.07 - World 7 - Pipe Land
=====

```

Map - Part 1/3

```

-----
+---+          +---+          +---+          Key
|ST|----O----O  |WP|          |WP|          ---
+---+          |  +---+          +---+          ST = Start
|          |    |          |          PL          TH = Toad's House
+---+ +---+ +---+ |  +---+ |          WP = Warp Pipe
| 1|--|WP| |WP|  TH  |WP|---PP---  PG = Picture Game
+---+ +---+ +---+          +---+          PL = Padlock
                                     PP = Piranha Plant Level
                                     (Numbers represent levels)

+---+ +---+          +---+ +---+
|WP|--|WP|          O---| 4|---|PG|----O
+---+ +---+          |  +---+ +---+ |
|          |          |          |
+---+ +---+ +---+          +---+
| 2|--|WP| |WP|          | 3|
+---+ +---+ +---+          +---+

```

NOTE: The Padlock disappears when you beat the Fortress level on the second part of the map.

Map - Part 2/3

```

-----
+---+          +---+ +---+ +---+ +---+          +---+          Key
|WP|          |WP| |FT|--|PG|--| 6| | 7|          ---
+---+          +---+ +---+ +---+ +---+          +---+          TH = Toad's House
|          PL  |          |          |          |          WP = Warp Pipe
|  +---+  |    |  +---+ +---+          +---+          PG = Picture Game
TH  |WP|---PP-----O---|WP| |WP| |PG|          PL = Padlock
      +---+          +---+ +---+          +---+          PP = Piranha Plant Level
                                     FT = Fortress
                                     (Numbers represent levels)

+---+ +---+          +---+ +---+          +---+
---| 4|---|PG|----O---| 5|--|WP| |WP|
+---+ +---+          |  +---+ +---+          +---+
          |          |
          +---+ +---+ |
          | 3|--|WP|  TH
          +---+ +---+

```

NOTE: The padlock disappears when you beat the Fortress level.



Map - Part 3/3

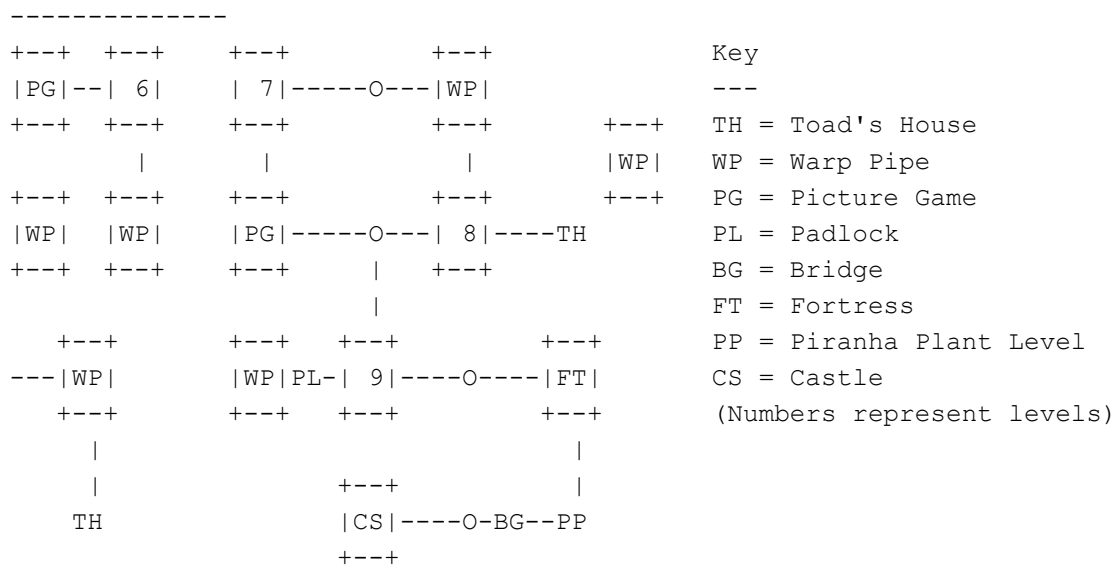

NOTE: The Padlock disappears when you beat the Fortress level.

World 7-1

-----  
 Jump onto the set of three pipes, go right and enter the doorway. In this next room you'll see a small pipe on the ground and to the left in the air is another small pipe with three '?' Blocks above it and a Red Koopa Troopa. From the first platform jump onto this and kick the Red Koopa Troopa away. Bash each block for a coin. Then, to the right you'll see another small pipe with two upside-down pipes above it. Jump onto this small pipe and enter either of the upside-down pipes. Next, you'll be in a secluded area of pipes. To the left are some horizontal pipes that have Piranha Plants peeping out of them. There's an upside-down pipe touching the pipe on the left; enter this when the Piranha Plant in the horizontal pipe is not looking out.

When you emerge at the other end of the pipe there are three '?' Blocks above you. They all hold coins. Drop onto the lower end of the pipe to your left and kick away the Red Koopa Troopa. Above you are two pipes side by side. Enter the one on the left. Next, you'll emerge at the side of a bending pipe with a Red Koopa Troopa and two '?' Blocks on it. If you have a Raccoon Tail I suggest swinging it against the blocks. The one on the left holds a Super Leaf, the one on the right a coin. Above this are some bricks and a '?' Block, which also has a coin. Only kick the Koopa's shell against these blocks if you plan on not getting the coin in the bricks, so you can safely get the shell.

Now, to the left you'll see a Music Note Block. If you bounce on this and hold the jump button so you go high, move right while in the air so you land on a floating horizontal pipe. Above you are two bricks, which are actually blocks that hold coins. Jump on top of these bricks and jump left onto the small pipe with the wooden block on it. Then jump through the gap in the pipes above you to get to the next level. Kill or just ignore the Koopa here.

On the right hand side of the screen are some more pipes, start climbing these. Watch out for Piranha Plants occasionally peeping out of them, though. Then make a jump onto the pipes to the left in the centre of the screen (look out for Piranha Plant in one of them). To the right in the air are two Music Note Blocks. Bounce on these to land on top of the pipe to the right (make sure the Piranha Plant isn't peeping out of it). There's another Music Note Block to the left and just above it here, too. Bounce on this so you can reach the two wooden blocks sticking out of the pipe arrangement.

Jump over onto the next couple of wooden blocks above and to your right and enter the pipe above them. Now this next part is a little tricky. To the left you'll see two Green Koopa Troopas approaching. Stand underneath the gap on the very right and when one Koopa approaches, stomp it and hold down the jump button so you actually fly up through the gap and onto the next part. Above these pillars of wood are some coins arranged like this: ^^ . Collect them and look out for the Red Koopa Paratroopa that hovers through one of the gaps. Once that's all done and dusted, enter the upside-down pipe on the very right end of the room.

When you emerge back into the overworld there are two pipes to your right. Jump over them and run right into the dark area, so you can get the card and finish off the level.

#### World 7-2

-----

Start by running right and jumping over the Nipper. Jump over the first pipe you come to that has white coins in it. Next you'll come to two '?' Blocks on top of two white blocks. You can kick away the blocks and do a running slide under the blocks and bash them while you slide through, swing them with a Raccoon Tail, or kick the blocks against them to be rewarded a Super Mushroom/Fire Flower and a coin.

Enter the next pipe you come to and swim to the very left into a room of coins and hit the P-Switch. You can then swim back out into the previous area and get the coins, then continue to swim right. Keep swimming past the pipe that spits the force bubbles out and enter the very next pipe you come to. To the right are four pipes in ascending height, and one of them has a Venus Fire Trap in it. Dodge its fireballs and kill it off if you have a Fire Flower, then climb over the pipes. Enter the second pipe that you see that goes through the ground, but before doing so, jump around in this pit to expose some invisible Music Note Blocks.

Once you've entered the pipe you emerge next to a '?' Block that has a Super Leaf Power-up in it. Grab this and go back to the previous area, go back to the four pipes going in height order and enter the pipe that goes into the ground. Swim left and enter the next pipe you come to so you re-emerge to the left of the four pipes going in height order. You can now cross the gap using the Music Note Blocks without worry of falling through and having to do it again.

Enter the next pipe after the row of Music Note Blocks. In this next area, go right and jump over the Nippers, then onto the platform you'll see after. Run right past the two pipes in the ceiling and bash the '?' Block for a Fire Flower if you need it. Now go back through the pipe you used to enter this area. Now start crossing the pipes and watching out for the occasional Piranha Plant, Venus Fire Trap and a Nipper. Near the end of all these pipes is a pipe that you should see going into the ground (fourth pipe from the end). Go down this one. You'll be spat out next to another pipe, enter this and you emerge at the dark area so you can proceed to run to the right and grab the card.

#### World 7-3

-----

NOTE: This is a really infuriating level in which you have to put up with Lakitu and the annoyance of his green eggs that follow you everywhere. I suggest skipping this level if you have a Jugem's Cloud, but if you have to, want to, or need to complete this level anyway, here's the walkthrough.

There is a '?' Block next to you when you start. Bash it to retrieve a Starman and run as fast as you possibly can to the right down the slope and killing all the Koopa Troopas and then you'll come to four '?' Blocks. Quickly bash the lower left one and if you are still invincible, another Starman will appear. Grab this, then use the top couple of blocks to jump over the gap and repeat the running process as you plough down some more Green Koopa Troopas and Paratroopas, then bash the same block as before for another Starman, and run down the slope, kill the Spiny, jump over the narrow gap and when the slope goes into a ramp at the end, jump onto the pipe to kill the Venus Fire Trap then jump the next gap.

Lakitu will appear here. In the '?' Block above the brick is a Fire Flower. If you get this you can take out Lakitu with a fireball or stomp him from the block that holds the Fire Flower. Run right, jump across a pit and bash the brick you come to for a P-Switch. Hit the P-Switch and some white coins will appear, so grab them quickly and be sure to evade Lakitu and the green eggs. If you have the Fire Flower, use fireballs to take out the green eggs.

Keep running to the right and you'll see a pipe lying on the ground with two bricks on each side, but don't dawdle trying to bash them; they only have coins. Keep moving right and now start to cross the ascending hill and be careful not to fall down the gaps. After that, there are two Green Koopa Paratroopas to get by and then the end of the level, where you can get the card and safely away from Lakitu!

#### World 7-4

-----  
Ah...the ol' Spiny Cheep-Cheep level. Start by entering one of the two crossed pipes to your right (they both lead to the same place, so it doesn't matter which one you enter).

Swim right and get the five coins, then under the formation of coral hoops on the wooden blocks, but beware of Spiny Cheep-Cheeps and a Lava Lotus. If you are Fiery Mario, you can toast the Spiny Cheep-Cheeps, although it bugs me on however Mario manages to use fireballs in water. But anyway, the next '?' Block you come to holds a Fire Flower Power-up if you did not have one already, and you can use this to kill off the Spiny Cheep-Cheeps. As you go right you'll encounter Big Bertha, so use Fire Powers against her if you can. And just be sure to move along with the screen as it goes.

After Big Bertha the screen starts to move upwards, then eventually to the right again. Now here's a tricky part; you have to swim through an immense school of Jelectros, while dealing with Big Bertha, and a couple of Blooper Nannies after that. The screen starts to move back down and when you see the ground you can move safe now.

Deal with some more Spiny Cheep-Cheeps, and after a column of coral hoops is a '?' Block that holds a Fire Flower. Now start swimming right again, under the coral hoops but avoid the Lava Lotus. Then you'll encounter another Big Bertha, so use fire or avoid her otherwise. Swim through the coral, collect the coins above the Lava Lotus and enter the pipe. You can now run right and get the card to end this level.

#### World 7-5

-----  
Enter one of the pipes at the start, they all lead to the same place. In the next room, kill or avoid the Green Koopa Paratroopa. Run right and deal with another Green Koopa Paratroopa, and enter the pipe hanging from the ceiling.

In this next room are some brick platforms with Koopas on them. Just ignore them, and enter the pipe on the right. Bomb-ombs will approach you in the next area, so kick them away and stay free from the explosions that they create. Doing a running slide under the bricks. Run right, kick away the white blocks, and carry on advancing right. Deal with the Green Koopa Troopas. Above are five '?' Blocks. Bash these for some coins and enter the pipe at the very end of this room.

Next, hit the '?' Block to the left for a Super Mushroom or Super Leaf Power-up. When you try to jump through the gap, you uncover an invisible coin block. Guess you can't get out this way. Go back down the pipe. Now hop onto the steel platform under the five blocks you bashed earlier, move left and enter the very first pipe you come to. Try to jump through the gap to uncover another invisible block with a 1-Up Mushroom inside it. When you see the mushroom emerge, very quickly go back down the pipe and enter the next pipe to the left and get the mushroom.

Now jump through the gap and move left until you get to the wall and go down the pipe. You emerge at where you started, but next to a '?' Block that contains a Fire Flower Power-up. Now jump back down to the area where you started and start running to the right again. And remember to keep an eye out for Bob-ombs! Now, go back up the pipe you used to grab the mushroom while it was moving towards you. This time, start moving to the right. Drop down the gap and enter the pipe at the end.

Grab the three coins and kill or avoid the Green Koopa Paratroopas here. There is a pipe in the ceiling here, half-surrounded by a 'L'-shaped formation of bricks and two '?' Blocks that both hold coins. Use these as stepping-stones to get inside the pipe.

Next part. Drop off the right end of the pipe and jump up to reveal hidden blocks, so you can't get back to the pipe from here. Run right and look out for the Bob-omb. To the right of the pipe are some white blocks with a Koopa Troopa trapped inside. Ignore this though, hop onto the platform and above are two more platforms. Try to jump through the gaps to reveal hidden blocks. Move left and use the next platform to climb up and run right across the higher platform. Drop off at the end and before you enter the pipe, jump up against the right wall to reveal a hidden 1-Up Mushroom! Get this, then go down the pipe.

You drop onto a formation of steel shaped like an 'L'. Drop off it and jump up around the gap between here and the steel pillar to your right to reveal a row of hidden blocks. Then go to the left and enter the pipe just left of the one you used to enter this room. You re-emerge in the area you were in just before, at the white blocks. Get through them and go around to the pipe you entered before. You can now run over the uncovered blocks and enter the pipe at the end of the room. Then it's all a matter of getting the card to finish the level off.

#### World 7 Piranha Plant Level (1)

-----  
Immediately when you start there is a pipe that you have to jump over, although it can't be done with a standing jump. You have to make a running jump and time it right so the Venus Fire Trap doesn't hit you. Then, do the same again for the next pipe. Across the gap you'll see some small pipes with Munchers that look out then go back in every alternating two seconds. So you need to make an accurately timed jump across so they're not looking out the pipes when you land. Now go across these sets of pipes and be careful when the Munchers switch, and look out for Piranha Plants when they stick out.



## World 7-6

-----

Run right, jump over the pipe and enter the doorway. In this next room, move left so you travel across to the other side of the screen. Start travelling up the stairs and get coins while you're at it. Look out for Green Koopa Troopas moving down the stairs, too. When you get to the top of the stairs, you'll see a pipe resting on top of two '?' Blocks, that both hold coins. Travel through the left side of the screen so you emerge on the right again.

To the left you will see a Music Note Block between two of the falling rings. Use this as a platform so you can jump onto the '!' platform to your right. It travels up, so jump on it to make it move to the left. When there is some open space jump on it again to make it move up. Then jump on it once more so it moves right, and you can jump onto the floating pipe. Above it is a '?' Block that holds a coin. Step on this so you can reach the platform that moves upwards. As it moves, stay on the left hand side so you go past the '?' Block with spikes on top. Then move onto the right hand side of the platform to go past another '?' Block with spikes on top.

Then you'll see a platform that moves left. Above it are two '?' Blocks that hold coins. Jump onto this platform and when it moves, jump onto the pipe just to its left, when the Piranha Plant isn't sticking out. Then, after the platform goes through the pipe, drop back onto it. It'll carry you through the screen, then enter the pipe on the right hand side when you come to it.

There is a platform moving to the left above you when you emerge in the next area. Jump on this and as it carries you to the left, bash the '?' Blocks just in the air above you. You get some coins and a Super Leaf as the reward. Then jump onto the '!' platform just below, this is more significant for travel through the level. Use it to get above the blocks you bashed and then through the gap in the spiked ceiling, then jump onto the platform moving left. Bash the two '?' Blocks underneath the right-moving platform for a couple of coins, then jump onto the platform moving up before jumping onto this one. Duck and bash the three blocks for coins if you want them.

When you are taken across to the other side of the screen, jump on top of the blocks. Bash the two '?' Blocks above you for a couple of coins, then jump on top of these blocks and make a jump onto the '!' platform to the right. Use it to travel through the gaps, and enter the upside-down pipe above the pipe with spikes on it. You can then run right in the next part, into the dark area, and get the card to finish off the level!

## World 7-7

-----

NOTE: This level is rather unorthodox. You must use continual Starman power to stay alive as you advance to the right.

Start the level off by entering the pipe to your right. Jump over the next two pipes when the Piranha Plants aren't sticking out. In the '?' Block is a Starman, grab this and run to the right as quickly as possible, over the plants. In the next '?' Block is a Starman; if you are Super Mario grab it by ducking while you are running to slide under and then jump to hit the block. Keep running right before having to jump through two sets of pipes and then bash a block next to a stack of wooden blocks for another Starman. Continue to run right, duck-slide under a very low hanging pipe. After jumping over a large pipe at the end, enter the pipe on the wooden blocks and run right into the dark area so you can get the card.

## World 7-8

-----

Run right and jump over the pipe (beware of the Piranha Plant inside it). In the air are two pipes with Venus Fire Traps in them, on top of four '?' Blocks, which you can bash for coins. Do a running jump to get over the next pipe, and then make jumps over the gaps and use the pipes to cross. Be very careful not to hit the Piranha Plants or get flamed by the Venus Fire Traps. Once you get to safe ground again, you'll see three '?' Blocks above the blue and pink platforms. The very left block has a Starman in it (get this!), and the other two hold coins. Go right, up three ascending pipes in height, and get past the Nipper on the brick platform.

Drop down and walk right. Get past the upside-down pipe when the Piranha Plant isn't sticking its head out, and watch out for the Ptooie (get past it by going through the gap made when it blows the spiked ball up high, or lure it out of the way). After that you'll come to a set of three pipes with a Ptooie patrolling them. Next to the set of pipes are two bricks; the one on the right is a multi-coin block. The next part is a bit tricky; you have to get past the Ptooie and Venus Fire Trap at once. Having Fire Flower power would help.

Now make a running jump to get onto the next pipe, but watch out for the Piranha Plant and Venus Fire Trap. Try to make sure neither are sticking out of their respective pipes. Cross the broken segments of bridge and don't fall or you'll suffer a fate of teeth marks. On the last segment of bridge you need to make a long jump onto the pipe to the right; it helps if you have a Raccoon Tail. Then make another jump to the right over a gap onto another pipe.

Next you need to get past two Ptooies; one in a pipe, and one walking. And then jump over the pipe (watch out for the Venus Fire Trap inside it). Then are some rows of bricks and '?' Blocks and a couple of Nippers. Avoid! One shoots a stream of fire! After getting past them you can run right and get the card to finish off this really frickin' annoying level.

## World 7-9

-----

Ah...another maze level. I love mazes. Start off by heading to the right and you'll come to three Music Note Blocks. Bounce on these to get through the crack in the pipe (hitting the middle Music Note Block reveals a Fire Flower). Anyway, jump through another crack in a pipe and kill the Red Para-Goomba, and jump through a third crack in a pipe. Then turn left and kick away the white blocks so you can get through. Go left and kick some more white blocks away again. Jump through the crack in the pipe and start moving right. Kill any Goombas you encounter.

At the end once you drop off you'll see two wooden platforms and a wooden block in the air. Use these to cross and stay on the top of the next part of the steel structure. Next time you drop off you'll see some Music Note Blocks, but this time, don't go to the top of the next part of the structure. Rather, kick away some white blocks on the left of the Music Note Blocks. Jump through the crack in the pipe, go left and kick away some more white blocks.

Drop down past the wooden blocks and move to the right. Kill or avoid the Green Koopa Paratroopa and at the next part you'll see three '?' Blocks. The left and right ones have coins in them, while if you are Regular Mario, you can bash the middle one for a Super Mushroom that will slide off for you to collect. Go right, jump up through the crack in the pipe and kick away some white blocks. If you're Super Mario, you can bash some bricks to get money, then head right and kick away more white blocks to get out into an open area of the structure, where you'll see some wooden block platforms in the air.

Use these to climb up and onto the ledge to the right. Kick away the white blocks and enter the next area. Get the coins and kick away the white blocks below the ones you just kicked away. You can bash the '?' Block here for a Fire Flower Power-up, then drop through the crack in the pipe. Collect the line of coins then move right and kick away the white blocks. Jump up through the crack in the pipe and drop down. Before you enter the pipe, go to the right to get some coins. Now enter it.

You'll emerge out of another pipe next to the dark area, so just travel on to the right and get the card to finish off the level!

#### World 7 Fortress (2)

-----

This level already starts off with a risk of losing a life. You need to make a long jump onto the pipe when the Piranha Plant isn't sticking out. If you have the Raccoon Tail it'll be a lot easier. You then have to make another jump onto a lower pipe to your right while making sure the Piranha Plant in that pipe isn't peeping out and keeping an eye on the nearby Boo Buddy. Then make a jump onto the pillar with the Roto-Disc circling around it, but keep your eye on the Boo Buddy. Then jump over onto the next pipe, and cross the lava pit using the bricks and jumping onto the next pipe, and from there, making a jump onto a taller pipe to the right when the Piranha Plant is inside.

From there, make another jump to your right onto a lower pipe and look out for the Piranha Plant inside it. You then need to cross to the next pipe while simultaneously avoiding the Thwomp above it. Do this by jumping as close to the pipe as you can so you trigger the Thwomp off, then jump onto it as it slowly moves back up, then make another jump onto the pipe to the right. Stand on top of the next pipe after this and make a long jump over the lava pit and Boo Buddy onto a set of pipes (look out for Piranha Plants in them).

Walk across them and then jump onto the next pipe and then get through the set of two pipes opposite each other when the plants aren't sticking out. Continue jumping across the pipes, and when you get to once with a '?' Block above it, bash it for a Power-up. Jump across to the next pipe and repeat the pipe-crossing/Thwomp avoiding routine like you did earlier. From the high pipe after the Thwomp, face left just so the Boo Buddy comes a little closer so you can safely make the next jump onto the next pipe. Then make another jump onto the steel pillar coming out the lava, then jump down and swerve left so you land on the pipe (easier if you have a tail), and then enter it.

Next, move to the right and you'll see a steel wall hanging from the ceiling with a small gap in the bottom, and a Roto-Disc going around. Wait for the Dry Bones to come through the gap, though. Make accurate timing, then run and slide under the gap but be careful for the Roto-Disc. Do this again but avoiding a Thwomp whilst doing so. Climb the staircase and drop off at the end. Move right a little and you'll encounter Boom-Boom.

There are three steel blocks in the room but these aren't much to worry about. Remember to be quick in your attacks on Boom-Boom. After one stomp he'll start slowly moving about but then make insane jumps, so make your stomps quickly. Three stomps as usual will destroy him so you can get the crystal.

#### World 7 Piranha Plant Level (2)

-----

Use the horizontally lying pipe to reach the next pipe when the Piranha Plant isn't sticking out of it. You then need to cross the small pipes with Munchers



coming out every few seconds, with a Venus Fire Trap at the end. After that, go past some pipes in the ceiling, then jump over the next pipe and you can use the Music Note Blocks and Red Koopa Paratroopa to get over the pit of Munchers. There is a set of three pipes at the end; go down the middle one. In this next room, touch the chest for a Super Mushroom and finish the level off.

#### World 7 Castle

-----

This time the king has been transformed into a Piranha Plant! So you start the airship as usual by climbing it. After you cross the deck you see another bolt on a long screw. Use this to progress across but watch out for the flamethrowers, but I usually jump across the platforms with the flamethrowers on, then you get to the next part of the ship. If you drop down and bash the '?' Block you get a Fire Flower Power-up. Next, use the bolt to get across the next part, avoiding the flamethrower. After the next part, jump onto the platform with the flamethrower in the middle then make the long jump back onto the ship.

Rocky Wrenches start attacking on the next part of the deck. If you hit the bolt on the screw underneath the platform it'll move out to the left so you can jump onto it and reach the '?' Block for a Fire Flower. Grab it if necessary, and carry on moving right. There's another little screw with moving bolt but really, you could just jump this part. Then make another long jump onto the next part of the ship and stomp Rocky Wrench. Carry on jumping across the various parts of the ship.

You'll then eventually come to a part with three screws. Use each different screw to advance across them then jump over the wooden pillar. You can then enter the pipe for your final Koopaling fight. For help with beating Ludwig Von Koopa, please read the Bosses section of this FAQ.

You receive another letter...but it's not from the princess!

```
+-----+
| Yo!           |
|               |
| I kidnapped the |
| princess while you |
| were running around. |
| She's here in my |
| castle,if you dare |
| to try and rescue |
|   her.         |
|               |
|               |
|   Ha ha ha...  |
|               |
|   Koopa Troopa |
+-----+
```

No prize jewel today, unfortunately.

=====  
3.08 - World 8 - Dark Land  
=====

-----

```

          +---+      Key
          |WP|      ---
          +---+      ST = Start
          PL        WP = Warp Pipe
+---+      +---+    |      TL = Tank Level
|ST|      |WP|      O      LS = Lava Ship
+---+      +---+    |      PL = Padlock
|          |        |
O-----TL-----O----LS

```

NOTE: The padlock disappears when you beat the Lava Ship Level.

Map - Part 2/4

```

          +---+      Key
          |WP|      ---
          +---+      WP = Warp Pipe
          |          DG = Dungeon Level
+---+      +---+    |      AL = Airship Level
|WP|----AL      |WP|PL--O      PL = Padlock
+---+    |      +---+
|
| +---+---+---+---+---+ +---+
O--|DG| |DG| |DG|--|WP|
+---+---+---+---+---+ +---+

```

NOTE: While moving across the dungeon squares, a hand can grab you at random and pull you into a level. You can also enter these dungeons optionally, although it is not necessary.

NOTE: The padlock disappears when you beat the Airship Level.

Map - Part 3/4

```

+---+      +---+      Key
|WP|-----O  |WP|-----O-----O-----O  ---
+---+    |    +---+      |    |      WP = Warp Pipe
          |          |      PL      FT = Fortress
          +---+      +---+    |    +---+    PL = Padlock
O----| 1|      |FT|----O  |WP|      (Numbers represent levels)
|    +---+      +---+      +---+
|          |
+---+  +---+      |          +---+
| 2|---|WP|-----O-----O-----O---|WP|
+---+  +---+      +---+

```

NOTE: The padlock disappears when you beat the Fortress Level.

Map - Part 4/4

```

          +-----+      Key
          |+++++|      ---
          |WP|---TL-PL--O-----O-----O---||CS||      WP = Warp Pipe
+---+      +-----+      TL = Tank Level
          |+++++|      PL = Padlock
          +-----+      CS = Castle

```

NOTE: The padlock disappears when you beat the Tank Level.

## World 8 Tank Level (1)

-----  
Jump onto the first tank and jump over to the second, and look out for the two cannons on it that fire horizontally and diagonally. The next cannon on this tank fires Bob-ombs, so jump over them or kick them away with caution and be careful not to get caught in their explosion blasts. Go past another cannon and Bob-omb cannon and some more cannons that fire diagonally. There is a flamethrower on the front of the third cannon as well as a Rocky Wrench inside, with a cannon on the end that'll fire Bob-ombs to the right.

Jump onto the next tank and stomp or avoid Rocky Wrench, who is inside the top. There is a short gap before the next tank, with a cannon firing horizontally on the front and another Rocky Wrench on top. There are two cannons on the front of the next tank, and one is on the ground, so time your jumping carefully. On the rear end of the tank is a cannon that fire Bob-ombs onto the ground. Be careful of these when you drop off the tank.

There is a Power-up available on the next cannon after Rocky Wrench; it's in the '?' Block (a Super Mushroom or Super Leaf). Grab it or not, and make a jump onto the next tank. There's a Rocky Wrench here and two cannons on the end that shoot cannonballs diagonally and Bob-ombs. If you have a Raccoon Tail, it is easy to get across to the next tank if you glide onto the top of the cannonball and float over.

The end of this cannon and the front of the next cannon both shoot Bob-ombs to the ground, beware of these, as well as a Rocky Wrench on the next cannon, and two cannons on the end. The bottom cannon shoots Bob-ombs to the ground. You'll have to go on the ground as it's a big gap to the next tank. Just stay away from the Bob-ombs (kick them away if they get too close). There is a cannon on the bottom of the next tank that fires in a trajectory on the ground, so be sure to jump in time!

Be careful in this next part, there is a giant cannon on the next tank that shoots giant cannonballs! So duck when you see it coming! On top of this tank is another Rocky Wrench and cannons that fire in opposite directions. Go past these and make a jump onto the final tank and enter the silver pipe on the top. Then, the level finishes off easy. Just defeat the Boomerang Brother in this room with one simple stomp or fireball, then pick up the chest it relinquishes for a Starman and to complete the level.

## World 8 Lava Ship

-----  
You start the level jumping on top of a cannon. A few steps to your right you'll see Rocky Wrench peeking, so stomp him to take him out. Jump on top of the next part of the ship, and look below to see a '?' Block being guarded by two cannons. This block contains a Super Leaf Power-up, so only get it if you really need it (it's risky though). Next, jump onto the cannon and stomp Rocky Wrench. Stand on top of the cannon here and make a jump to the next part of the ship.

Take out Rocky Wrench, and to your right you'll see a giant cannon. To the right is a big gap to cross to the next part of the ship. Make sure you are not in the cannonball's path when you do that. You can actually leap into the lava and jump back out again onto the ship.

Jump onto the cannon next to avoid being blasted, then jump onto the next cannon. Stomp Rocky Wrench and jump onto the two wooden pillars to the right

then move across to the right, while avoiding wrenches being thrown by Rocky Wrench. Then, is another giant cannon. Make sure it has fired before stepping down and making the jump onto the next part of the ship, which also has another giant cannon on it, so jump on top of it when you see it appear on the screen!

To the right you'll see a Bob-omb cannon, and to the right of that are three cannons lined like steps. These fire cannonballs in order from lowest to highest. Jump over when it's safe. Then, make a jump over the little gap and after one last giant cannon, enter the silver pipe to meet Boom-Boom. You know what to do. Three stomps to get the victory.

#### World 8 Dungeon (1)

-----  
You start on one end of a bridge with a Fire Brother on the other end. Stomp him or flame him or jump over him and drop down onto the next bridge. Go right and you'll see the Hammer Brothers on two brick ledges. Take them out by bopping them from below to avoid being hit by their annoying hammers. On the bottom row of bricks, hit the third from the right to reveal a Power-up and hit the two on its right for coins. Bash through the higher row or jump up onto it to advance right onto the next bridge. Take out the Boomerang Brother if you can, and go right to meet a Sledge Brother. Take him out if you can, then enter the pipe to the right. Touch the chest to the right in this next room to get a Super Leaf and automatically end the level.

#### World 8 Dungeon (2)

-----  
Climb the steps, hop onto the broken bridge and start jumping across the big lava pit, using the broken bridge segments as stepping-stones, and watch out for the Podoboos jumping up from below. Grab coins in the air while you jump, then finally jump onto the steel ground and enter the upside-down pipe. Touch the chest for another Super Leaf and to end the level.

#### World 8 Dungeon (3)

-----  
Head right and step onto the bridge. Cheep-Cheeps will start flying up at you, just like in SMB1. In the two '?' Blocks on the first segment of bridge are coins, before you have to start making more jumps across the lava using the bridge segments as stepping-stones while avoiding the Cheep-Cheeps. After the bridge with two wooden blocks floating just above it is a bridge segment with a '?' Block above it. Bash this for either a Super Mushroom or a Super Leaf. Then run right and go through the wooden obstacles. Jump across a few more bridge segments then you'll see a row of coins shaped like '^ ^ ^'. Get these then enter the pipe at the end of the room to get the chest and a third Super Leaf.

#### World 8 Airship Level

-----  
No wonder Bowser is hated so much...he has to have the toughest levels in his land. This one is one of the toughest by far. The screen scrolls at a very fast pace, so a Super Leaf, or even better, a P-Wing is very strongly recommended. It'll make this level literally like, five times as easy.

The first segment of the ship you start on has a Rocky Wrench and flamethrower on. You won't have time to make any stomps, so just make quick jumps over to the second, then third part of the ship, which has a little stump on it. Make a long jump onto the next part of the ship (look out for Rocky Wrench), jump onto the wooden pillar and make another jump to the right onto the next part of the

ship.

From this next part, make a jump to the right to a higher area of ship and carry on jumping to the right while looking out for Rocky Wrenches and flamethrowers. After some more little segments of ship you come to one with a big crate on it. Use this to jump onto the next part, which is rather high, then jump to the next ship segment near the bottom of the screen and make a long jump to your right onto the next ship segment. Make another high jump, then down low again and keep jumping right and just avoid these wrenches being thrown. Then on the last part of the ship, enter the silver pipe to meet Boom-Boom.

Yet again, three stomps is all it takes to beat the guy. Just bear in mind that he'll grow wings after one stomp, so be quick to stomp him again to make him lose them, then when you have finished him off, grab the crystal to take the padlock off the map.

World 8-1

-----

Go right and jump over the gap. The first '?' Block you come to has a coin in it. Step on top of this to jump onto the pipe here when the Venus Fire Trap isn't sticking out. Then make a jump to the right onto the next pipe when the Piranha Plant isn't sticking out of it. Repeat again onto the next pipe (avoid Venus Fire Trap in this), again to the right onto a pipe floating on top of some wooden blocks, then jump down to the ground.

Head right and you'll see two rows of bricks, a Green Koopa Paratroopa, and some Bullet Bill cannons. Use the brick rows to jump over onto the top of the cannons. Then to the right is another stack of Bullet Bill cannons to jump onto (I wouldn't go for the '?' Block, it's too risky), then jump onto the ground underneath the steel.

Head right and jump onto the cannon. Above you are lots of '?' Blocks and a brick. The brick actually holds a 1-Up Mushroom, and the '?' Blocks hold coins. Keep an eye out for the nearby Boo Buddy. Go right and pass the cannon being held up by the metal (run under if you are Regular Mario, run and slide under it if you are Super Mario). Bash the brick you see here for a Super Leaf Power-up, then jump over the pit and you'll come to a couple of green platforms.

Kick away the Red Koopa Troopa on one of these platforms. Above the higher platform are two '?' Blocks, these contain coins. Jump right, over the next gap and bash the '?' Block next to the pipe for a coin. Then, jump over the pipe here (avoid the Venus Fire Trap inside it). Now go right, past the Green Koopa Troopa and you'll come to a Bullet Bill cannon. Stand on top of this. To your right is a big gap that can only be completed if you get over the high stack of Bullet Bill cannons. Bounce on the Red Koopa Paratroopa's head and hold the jump button down so you bounce high and you should be able to make it.

When you land, drop down and collect the coins and jump over the next stack of cannons to your right (be careful for the Bullet Bills that they fire). There's an invisible block that should help make the jump. Next part is really tricky. You'll see, on the end of the ledge, a Music Note Block, to the right: a large gap and a giant pipe that can't be made by an ordinary jump. So, get a good run up, make a jump onto the Music Note Block and bounce while holding right so you can get onto the top of the pipe!

Now, make another jump over the pit onto another pipe whilst making sure the Piranha Plant inside it is not sticking out, drop off and run right into the

dark area to collect the card and finish this god forsaken level!

## World 8-2

-----  
Run right, go up the slope and jump over the quicksand. Go right, down the sand steps and look out for the Red Para-Goomba. Go right, up the next slope and jump over the three quicksand pits with Venus Fire Traps in them. Go down the slope but watch out for the Venus Fire Traps halfway down. In the brick next to one of the Venus Fire Traps is a P-Switch. Quickly hit this and start running right as quickly as possible.

The Angry Sun then appears! Cross the vast pit using the bricks that have appeared from the coins when you hit the P-Switch. Remember that they'll soon become coins again though! Use the Music Note Blocks if that happens. Once you've cleared the gap, start going uphill and watch out for the Venus Fire Traps.

At the top of the hill are three coins to grab, then go down the slope. Cross the next pit by bouncing on the Koopa Paratroopa's head and the Music Note Block. Then run right and while avoiding the Angry Sun, head into the dark area and get the card.

## World 8 Fortress

-----  
By far the most mazy and difficult of all fortresses. Ah well, here we go anyways. Move to the right, jump onto the high ledge and drop down to the right and go past a Roto-Disc. After the next pillar, you can bash the brick for a coin and you'll come to two alternating Roto-Discs. Get past these and jump on top of the steel enclosing the door in the ground. Bash the brick above you for a Power-up. Go right, past two more Roto-Discs. Jump over the steel pillar and stomp the Dry Bones located here. Now that you are Super Mario, bash the bricks around the orb that the Roto-Disc is orbiting and enter the door encased in the bricks.

Think fast! You appear on a conveyor belt touching a boiling pool of lava. Make a jump to the right onto the steel in the lava. Jump onto the next steel island (don't enter the door though). Jump across the conveyor belts to your right until you get to the steel and see a Thwomp. To the right of him should be a '?' Block. Bash this for a Super Mushroom/Super Leaf Power-up. Continue moving right, jumping across the conveyorbelts until you get to a steel platform above the right end of the lava pit with a door; enter this.

In this next room, walk right and you'll spot a P-Switch. Hit this, and now start running to the right as quickly as possible. After all the obstacles that you should just get past at top speed while jumping the Dry Bones, you'll spot a white doorway at the end of the room; quickly enter this.

Go right, past the Boo Buddy and go to the end of the conveyor belt. Below you'll see a Thwomp moving horizontally. When he moves back into position, jump down, head left and jump over the steel stump and run left. See the two bricks holding the conveyor belt? Hit the one on the right, and a P-Switch will be revealed. Get back up and hit this P-Switch and a white doorway will appear on the conveyor belt. You can quickly go into the room it reveals to achieve a Fire Flower Power-up, then head to the end of the conveyor belt and jump right onto the steel block sticking out the wall and enter the doorway that appears here.

In this next room you'll fall onto a conveyor belt. Duck and it'll carry you

right, under a set of spikes and then, another encounter with Boom-Boom! It's just fighting on the conveyor belt that you've got to be really worried about, although this guy ain't not so much of a tough cookie. Use the simple three stomps/five fireballs routine to knock him out and get the crystal to finish off the level.

#### World 8 Tank Level (2)

-----  
You're now at the castle walls, so get yourself prepared. The first tank immediately approaches you, with a cannon on front. Jump on top of it. Above and to the right is another segment of tank with a cannon on its roof that fires cannonballs down at you, so avoid them. On the tank you are standing on are three cannons firing cannonballs upwards. Get past these, and then you'll see another cannon in the ceiling above you, a Bob-omb launcher, and two horizontally firing cannons to the right. Interpret and avoid the cannonballs and Bob-ombs before moving onto the next tank.

There are Rocky Wrenches all over this next tank; they're all easy to get away from as long as you keep an eye out for the nearby cannon up at the higher end of this tank. Then, jump onto the ground and above you'll see three cannons. Two of them shoot in your path, watch out for these. Onto the next tank - after the first three cannons on it you'll come to a Bob-omb launcher, another cannon and two cannons firing horizontally. Climb onto the end with the two horizontally laid cannons and stomp the Rocky Wrench. Apres ca, make a jump onto the next tank and go down the silver pipe.

Not him again! Don't worry, this'll be your last Boom-Boom fight and they made it easy for you! Yay! Just use the simple three stomps to take him out, but just remember that he'll grow wings after one stomp, so be sure to do this quickly, and after you beat him and get the crystal, the path is laid out for you to enter into Bowser's castle...

#### World 8 Castle

-----  
Start the level by making a big run to the right at full speed, filling up the P-Meter and going past the Gray Bowser Statues that fire lasers directly down at you. If you have a Raccoon Tail, it would be a better choice to fly over them as you still may get caught if you run under them. Now, climb the staircase and you'll see a gap in the ceiling. Stand directly under this and a lift will out of nowhere appear and take you up. Once it's at the top, jump into the tunnel to your right.

Move right and you'll see a falling ring blocking a drop down. Stand on it and as it drops hold Right on the D-Pad so you go into an alcove. Move right and go past the Hot Foot. Start climbing the steep staircase and avoid the Roto-Discs on it. At the top of the staircase, drop down the gap to the right and go down the staircase while avoiding the Roto-Discs from the other side.

Run right through the tunnel and you'll come to a big lava pit with some falling rings above it. At the right end of this lava hallway are four alcoves. Take either the top one or the third one down. The second one down has a Power-up and a falling ring that'll take you down to the third alcove so you can continue moving on. If you take the top alcove, follow the Route 1 walkthrough. If you take the third alcove, take Route 2.

#### Route 1

-----

Run right and look out for the Gray Bowser Statue. Jump on top of it and jump

across the Gray Bowser statue. Some won't fire lasers though, so that's not too bad. After advancing past the statues, you'll see fireballs moving from one side of the screen to the other, and if you remember which game this was from, you can tell that Bowser's not far away! Cross the lava pit using the falling rings as stepping-stones, but be quick while you do so! After the pit you'll see that Bowser's not there, but a doorway is...go through this doorway. Scroll down to the end of Route 2 to carry on with the walkthrough.

#### Route 2

-----

Go right and avoid the laser that the Gray Bowser statue will fire at you. Hop on top of it, jump over the second Gray Bowser statue and bash the '?' Block for a Power-up. Advance past some more Gray Bowser statues before eventually arriving at a lava pool. Flames will come across the side of the screen towards you. Interpret these as you cross the lava pool using the floating bricks. After getting across the pool you'll come to a doorway; enter this.

#### Routes join up here

-----

Time for the final boss battle! Read the Bosses section of this FAQ for help on winning. Once you beat Bowser, you've done it!

Congratulations on beating Super Mario Brothers 3! I'm not going to spoil this ending for you, so sit back and enjoy! Well done on completing the game!

=====

## 4. Enemies

=====

For easy navigation through this list, all enemies are arranged in alphabetical order. Thanks to TMK for most enemy descriptions and names for most of those I was unsure of.

#### Angry Sun

-----

The sun in the sky that swoops at you. He can only be taken out with a shell or by grabbing the card at the end of the level.

#### Baby Cheep

-----

Small fish that are spat out and sucked in again by Big Bertha.

#### Big Bertha

-----

Similar to Boss Bass, but they can spit out Baby Cheeps, which can also harm Mario.

#### Blooper

-----

From SMB1 with a totally new design. They're shorter and swim around faster, but still as cheesily difficult to get by.



### Blooper Nanny

-----

Same as Blooper, but carries babies with it. Don't touch the babies either.

### Bob-omb

-----

Back again from SMB2, these walking bombs will move around for a short while before lighting their own fuses. They'll rapidly grow and shrink before exploding. You can stomp them and kick them to take out other enemies in a similar fashion to what you did in SMB2.

### Boo Buddy

-----

These ghostly enemies that can't be harmed will freeze when your character is facing them but chase you when your back is turned. Keep a close eye out at all times...

### Boomerang Bros.

-----

A new enemy in the Mario games that made its debut here, this guy throws boomerangs at you, but they are not difficult to avoid. Taken out usually by the same method as taking out Hammer Bros.

### Boss Bass

-----

Those really big fish that appear in water levels and stalk you about, they're looking for a bite! No matter whether you are Regular, Super, Fiery, Raccoon, or any other type of Mario, you will be killed instantly in one swallow from this fish. So stay away! A fireball takes it out though.

### Bullet Bill

-----

They appear in SMB1, either as enemies flying from the side of the screen in a particular level, or shot from cannons. Here, they are shot from cannons.

### Buster Beetle

-----

These blue beetles have the ability to pick up white blocks and throw them at Mario.

### Buzzy Beetle

-----

Another SMB enemy, who usually appear in dark or cave areas. They behave like regular Red Koopa Troopas, but cannot be hurt by fireballs.

### Chain Chomp

-----

Those gnashy dudes that are held back by chains so they don't have a broad reach. But don't get too close; these guys have a rather vicious tendency to bite anything that comes in sight.

### Cheep Cheep

-----  
An old enemy from SMB, who appears in water. They can be found in green and red.

### Colossal Koopa Paratroopa

-----  
These huge Koopa Paratroopas may look intimidating but really are just taken out the same way as a normal Koopa Paratroopa would. They come in two colours: Red and Green.

### Dry Bones

-----  
These are the skeleton form of a Koopa Troopa and are a new addition to the Mario series. When you stomp them, they will collapse but soon be restored to life.

### Fire Bros.

-----  
These guys shoot fire from their mouths, which is rather difficult to overcome, but they can be easily taken out with a simple stomp.

### Fire Chomp

-----  
Black balls with mouths and a fire tail. You can stomp them but if you take too long in doing so they explode. Be somewhere else when they do so!

### Fire Snake

-----  
Snakes of fire that chase you around in the desert levels and can climb and go through obstacles. They can be taken out with the power of invincibility, or the swing of a Raccoon Tail.

### Goomba

-----  
Remember this guy from SMB? Well, although he didn't make an appearance in SMB2, he's back now, and has an ever-so-slightly new appearance. He's still killed the same way as before: a simple stomp or fireball, but can also be taken out with tail whips, shell kicks, and most other attacks.

### Grand Goomba

-----  
It's only being tall that's different about them. Despite the size, they're just about the same as regular Goombas.

### Gray Bowser Statue

-----  
These are the statues found in Bowser's castle. If they spot Mario in their eyesight they'll fire lasers at him, so run past as quickly as you possibly can.

### Green Gargantua Koopa Troopa

-----  
These are the especially humongous Green Koopa Troopas you see in World 4. However, they are exactly the same as a normal Green Koopa Troopa, only bigger. They are killed in the same method as a normal Green Koopa Troopa, too.

### Green Koopa Troopa

-----  
Like the Goomba, these guys appeared in Super Mario Brothers, and did not appear in Super Mario Brothers 2. Here, they are taken out the same way as they were in SMB, a simple stomp and a kick of the shell.

### Green Koopa Paratroopa

-----  
These ones aren't so good at flying, so they tend to bounce in arcs or sometimes horizontally. Stomp them once to make them lose their wings, and they become normal Green Koopa Paratroopas.

### Hammer Bros.

-----  
Often seen in pairs in SMB, these now usually appear alone in this game. You can find them hanging around on the map screen or in levels. They throw hammers at Mario, but are a little easier to evade than in Super Mario Brothers.

### Hot Foot

-----  
The candles in some fortresses release their flames, which come to life, these are Hot Foots. You cannot kill them unless you have invincibility, a Hammer Brother suit, or swinging them with a Raccoon Tail.

### Jelectro

-----  
An electric Blooper that doesn't move, but can be a pain to get by in some areas. Learn how to swim around them.

### Kuribo's Goomba

-----  
All in the name. A Goomba in a Kuribo Shoe. Take him out to get the shoe for yourself.

### Lakitu

-----  
From the original SMB he stays true to his attack methods. He'll drop red or green Spiny eggs from above and try to hit Mario. You can stomp him or hit him with fireballs to temporarily take him out, but he will return sooner or later so progress as fast as you can while he is out of action.

### Lava Lotus

-----  
Plants that appear in water levels, and like to release little lava balls at you, which are a must-avoid. However, they're rather easy to escape from.

### Missile Bill

-----

Similar to Bullet Bills, these flash and home in on Mario. You can stomp them to take them out like regular Bullet Bills, and stand next to their cannons to prevent them from being fired, too.

### Mugger Micro-Goomba

-----

These REALLY small Goombas aren't so strong enough to attack, but they will attach themselves to Mario or Luigi's body, and reducing their running and jumping. To shake them off, just repeatedly and quickly tap Left and Right on the D-Pad.

### Muncher

-----

These small black plants with jaws cannot be hurt, however you can turn them into coins if you hit a nearby P-Switch.

### Nipper Plant

-----

These white plants stay in one place at a time, and when you jump over them they'll jump up and try to bite you. You can take them out with the use of a Raccoon Tail, though. Don't try stomping!

### Piranha Plant

-----

They appear inside pipes and pop out to attack Mario. Some just flap their jaws around, some spit fireballs, and some can attack from pipes hanging from the ceiling.

### Piranhacus Giganticus

-----

Giant Piranha plants that are specifically found in World 4. There is no difference between them and normal Piranha Plants, just the size.

### Podoboo

-----

Remember these from SMB1? They were the balls of fire that jumped out of lava pits to try to scorch Mario. And here...they do the same. They cannot be killed, like in SMB.

### Ptooie

-----

These plants, found in pipes or moving around, blow up a spiked ball and balance it in the air. You should jump between them when it blows the ball up really high to create a big enough gap.

### Red Giant Koopa Troopa

-----

Giant Red Koopa Troopas. Only the size that's different. They are killed in the

exact same way as a regular Red Koopa Troopa.

#### Red Koopa Paratroopa

-----  
These tend to fly vertically over pits. They are taken care of the same way as Green Koopa Paratroopas.

#### Red Koopa Troopa

-----  
Another of SMB's antic foes who's back in SMB3. They are the same as their Green counterparts, but they don't walk senselessly off ledges.

#### Rocky Wrench

-----  
They appear on the airships, often hiding inside the flooring. They pop up and hurl spanners at you, but aren't too difficult to dispose of.

#### Roto-Disc

-----  
The energy balls that move in circles in Fort levels. They cannot be killed.

#### Sledge Bros.

-----  
These extremely huge Hammer Brothers can toss hammers but also have a rumble jump. So when they land on the ground, make sure you're not on it, as you'll be temporarily stunned, leaving you wide open for attack.

#### Spiny

-----  
Back again from SMB. These red hedgehogs hatch from red Spiny Eggs that are dropped by Lakitu and move around in any direction like a Goomba. He cannot be stomped, but you can use invincibility, fireballs, or a tail swing to knock him out.

#### Spiny Egg

-----  
These come in two colours: Red and Green, and are dropped by Lakitu. Red ones drop straight down and hatch into Spinys when they hit the ground. Green eggs fly in any direction and do not break when they hit the ground, but will roll at Mario, so you had better be on your toes to get away from these. Fireballs will do the trick, though.

#### Spiny Cheep-Cheep

-----  
These spiny fish are quick and try to harm Mario in the water. Use fireballs to safely take it out. They are only in World 7-4 though, so feel relieved once you've finished this level!

#### Stretch

-----  
This is a long white bar, which grows Boo Buddies out of it that move around on

the surface.

#### Thwomp

-----

Another new addition to the Mario series that made their debut in this game. Thwomps drop directly down at a fast speed, intending to crush Mario or Luigi. However if you stand a little distance away from directly below the Thwomp's dropping path, it should come down but you will not be hit. You cannot kill these enemies.

#### Venus Fire Trap

-----

A Piranha Plant-like creature that spits fireballs at Mario at a slow speed. You can take them out with fireballs and tail attacks.

=====

### 5. Bosses

=====

#### Larry Koopa

-----

Your first Koopaling boss fight. And it's not a tough one either. Larry fires circular waves from the wand, so these are the only major things to avoid. He jumps around the room too, so evasion is the key. When you stomp him on the head he'll retreat into his shell and jump around the room, so be sure to avoid him. When you stomp him three times he'll spin away and drop the Magic Wand. Fireballs are also a good method of beating him, but it takes a lot of fireballs, so stomping is a better method. Grab the Magic Wand and you are automatically returned to the castle.

#### Morton Koopa

-----

Ok, so this guy isn't that tough. He's almost identical to Larry, but has a lower but broader jump. Just attack the same way as you did with Larry. A few stomps and fireballs here and there, and you'll do fine. When he drops the wand, grab it!

#### Wendy O. Koopa

-----

At the start, Wendy will fire a ring that flies around the room. Avoid this at all times. Stomp her and she'll fire another, so you'll have to be twice as wary now. Stomp her a third and final time and the rings will disappear and you can achieve the Magic Wand!

#### Iggy Koopa

-----

Iggy tends to make quick, low jumps, and fires rings at a high speed, but not too often. When you stomp him twice, he'll start jumping very high so just watch out here, although it won't be much of a problem. Just keep your distance and stomp him good to get the wand back.

#### Roy Koopa

-----

Roy has a rumble jump attack similar to that of a Sledge Brother. So watch out when he jumps. He hasn't got good jumping power, but when he lands on the ground it'll shake and temporarily stun you, and you cannot afford for that to happen. So jump when he lands on the ground, and avoid the rings he fires from the wand. When he retreats into his shell and jumps around that'll cause a quake too, so beware of that. When you stomp him three times, get the wand to return to the castle and receive a letter from the Princess.

Lemmy Koopa

-----  
This guy is relatively easy, surprisingly. He'll roll around his flat room on a ball and fire more balls at you. You can bounce on top of these balls and you won't get hurt, but just don't let them hit you from above. When you stomp him three times, he's history and you return to the castle and receive another letter from the princess.

Ludwig Von Koopa

-----  
Ludwig Von Koopa is really just about identical to Roy. He has poor jumping and can make rumble jumps when he hits the ground. He is bigger and easier to hit, therefore. Just do the usual three stomp and look at Roy's strategy on how to beat him, then you get the wand and return to the castle.

Bowser

-----  
It's time to give this brute the punishment he deserves. In the middle of the room is a big cluster of bricks, and Bowser will appear on the right hand side of the room, next to a locked door. Stand in the middle of the brick cluster, and as he fires flames at you, jump, duck or avoid them, then he'll launch himself into the air. Quickly jump out of the way and he'll come down with a massive ground pound and sabotage some of the bricks. He'll fire some more flames at you, so avoid them, and wait for him to go back to the platform above the door. Repeat the process again. Once he's cleared a whole gap in the bricks he'll fall through and make a rather nasty fall to only the Mushroom God knows where he'll land! After the big thud that follows, the locked door will open. Enter it.

=====  
6. Items  
=====

Listed alphabetically for easy navigation like the enemy list.

1-Up Mushroom

-----  
Similar in looks to the Super Mushroom, only these have green dots on top, rather than the Super Mushroom's red. Picking one of these up will give Mario/Luigi an extra life.

'?' Crystal

-----  
Boom-Booms hold these. Hence you defeat Boom-Boom, he'll relinquish it. Pick it up to finish the fortress level and unlock a padlock on the map.

## Anchor

-----

Use this to pin down the airships on the map. Quite handy, but rare.

## Coin

-----

These things are scattered about the entire Mushroom World, and can either be found just lying about in the overworld or hidden in blocks. They were also seen in SMB and SMB2. Like in SMB, collect 100 of these and you will gain an extra life.

## Fire Flower

-----

Another of SMB's antics. Grabbing one of these will make Super Mario become Fiery Mario, and gives you the ability to flick fireballs.

## Frog Suit

-----

When Mario is wearing one of these, he will be able to swim much more smoothly by using the D-pad directional buttons. Not much use on land, though.

## Hammer

-----

Another item used on the map screen, this allows Mario/Luigi to smash rocks to visit extra, or hidden parts on the map screen.

## Hammer Brother Suit

-----

With this on, Mario can throw powerful hammers. What more?

## Jagem's Cloud

-----

These items are used on the map screen. They allow you to bypass a level. They are quite tough to find though, so saving them until a dire difficult level to get by is probably the best idea.

## Kuribo's Shoe

-----

The rarest of all items, and only in World 5-3. Pity. Allow you to stomp tough enemies, cross rough surfaces and looks pretty cool to travel in.

## Magic Wand

-----

Each of the Koopalings has stolen a Kingdom's king's magic wand and used it to transform the king into an animal. Your goal is to get these back. When you defeat a Koopaling, it'll relinquish this item.

## Music Box

-----

Used on the map screen only, this sends all Hammer Brothers, Boomerang Brothers, Fire Brothers and Sledge Brothers to sleep so you can easily sneak



past without any difficulty.

#### Music Note Block

-----

These bouncy blocks can give Mario a spring, and sometimes contain hidden items.

#### P-Switch

-----

When you get one of these magical switches they'll turn all bricks into coins and all coins into bricks. They can also make invisible white coins appear!

#### P-Wing

-----

Activate it on a map screen, and Mario/Luigi start flashing. Pick a level, and you'll see that Mario/Luigi have a Raccoon Tail on, and the P-Meter is full. Get the idea? In other words, you can fly about for the whole level.

#### Red Music Note Block

-----

When Mario bounces on these, hit A and you'll go soaring into coin heaven!

#### Starman

-----

Also from SMB and SMB2, grabbing one of these will grant you the power of invincibility for a short time. But what's new, if you jump while in the possession of a Starman, Mario and Luigi do somersaults!

#### Super Leaf

-----

Snagging one of these will make Mario grow a raccoon tail. This thing has some good powers, if you press the B button, Mario will swing around, and the tail will knock out most enemies that come in contact with it. While falling, repeatedly tapping the A button will make Mario glide with the tail to fall at a slower rate. If you get a good run up and fill the P-Meter, you can fly with it if you hit the A button quickly and repeatedly.

#### Super Mushroom

-----

Also from SMB. Touching one while Regular Mario will turn him into Super Mario. If hit while Super Mario, you will become Regular Mario again. They are white mushrooms with red spots on top.

#### Tanooki Suit

-----

This is the same as a Super Leaf, only if you hold the Down button on the D-Pad and the B button, Mario will temporarily become a statue and cannot be hurt.

#### Warp Whistle

-----

There are very few of these coveted items in the whole game, and they're

usually well hidden (but not hidden well enough so that this FAQ couldn't expose them. Heh heh). These whistles allow you to warp to a screen that allows to you to pick a world from 2 to 8. There are three rows. If you are warped to the higher row, you can warp to World 2, 3, or 4. The middle row lets you access World 5, 6, or 7. The bottom one lets you get to World 8.

=====  
7. Secret Areas  
=====

These are all the secret areas and fun things to discover in Super Mario Bros. 3.

-----  
7.01 - Mario Bros. Mini Battle Game  
=====

In a 2-Player Game, when one person is playing, move to your partner's counter and press the A Button to enter a Mario Bros. Battlefield. You attack your opponent and take out 5 enemies. The first person to get most coins in their counter wins. You can steal cards your partner is holding, and have them transferred into items in your inventory.

-----  
7.02 - Warp Whistle Locations  
=====

Secret Warp Whistle in World 1-3  
-----

Before the end of the level, you'll see a white platform in the air. Kick the Koopa off and duck on top of the block. Keep crouched for a few seconds and you'll fall through and land behind the scenery. Quickly run right and behind the dark area. You'll enter Toad's house. Open the chest to get the Warp Whistle.

Secret Warp Whistle in World 1 Fortress  
-----

At the end of the first room in the Fortress is a '?' Block just after a lava pit, and before a Dry Bones. If you are Super Mario you can bash the block for a Super Leaf. Fill up the P-Meter by running around and fly up the wall above the block. Hold right until the screen moves, and run right until the screen stops moving. Now press Up and you will enter a door that you can't see. You'll automatically arrive in another room. Touch the chest to reveal a Warp Whistle.

Secret Warp Whistle in World 2 Hammer Brother Battle  
-----

On the World 2 Map Screen, there is a rock in the upper-right corner of the area. Smashing it with a hammer grants you access to a small area with a Hammer Brother wandering about. Enter battle, and when you win, a chest will appear. Open it to get the third and final Warp Whistle of the game.

Quick Route to World 8  
-----

Get two Warp Whistles (one in World 1-3 and the other in the World 1 Fortress).

Ok, when you are on the map screen, press B to view your inventory, and select the Warp Whistle to visit Warp Zone. In Warp Zone, don't visit any Worlds. Instead, press B to go to your inventory again. Choose the other Warp Whistle and you will be brought to Warp Zone again but you are on the bottom row. You can now enter World 8.

=====  
7.03 - White Mushroom Houses  
=====

These very rare houses are found only once in a world (apart from World 8). In a certain level you must collect a certain amount of coins to get to a White Mushroom house. You'll be rewarded a P-Wing or Anchor here. Here is a list of levels and the amount of coins needed to get to each World's White Mushroom House.

World 1

-----

Get 44 coins in World 1-4.

World 2

-----

Get 30 coins in World 2-2.

World 3

-----

Get 44 coins in World 3-8.

World 4

-----

Get 22 coins in World 4-2.

World 5

-----

Get 28 coins in World 5-5.

World 6

-----

Get 78 coins in World 6-7.

World 7

-----

Get 46 coins in World 7-2.

There is no White Mushroom House in World 8.

=====  
7.04 - Coin Ship  
=====

A very rare secret, and I've only managed to get this three times. You need to be in World 1, World 3, World 5 or World 6. There must be at least one Hammer

Brother on the map. You have to get your coin total in a certain level to a multiple of 11 (11, 22, 33, 44, 55, 66, 77, 88 or 99). You need to 10's digit in your score to be the same number as the 10's digit in your coin total (if you have 33 coins, your score would need to be 0015630). Then you need to finish the level with the timer on an even number. The Hammer Brother on the map will then transform into the coin ship. The ship has coins everywhere for 1-Ups. Just before the pipe on the very right end, there is an invisible block with a 1-Up Mushroom in the air a couple of steps to the left of the pipe.

```

=====
                          7.05 - Card Game Solution
=====

```

For every 80000 points you achieve an N-Spade card will appear on a map. When you enter it you will play a game of 'pairs' in which you flip over two cards to see if they match. They contain symbols from in-game items. So, for example, if you get a pair of Starman cards, you are rewarded a Starman, and an extra life if you get a 1-Up Chest, etc. If you miss twice, you're out and return to the map. There are eight different layouts of the cards, like so:

Key

- ```

---
10 = 10 Coins
1U = 1-Up
20 = 20 Coins
FF = Fire Flower
SM = Super Mushroom
ST = Starman

```

Pattern One

```

-----
+---+ +---+ +---+ +---+ +---+ +---+
|1U| |SM| |10| |SM| |FF| |ST|
+---+ +---+ +---+ +---+ +---+ +---+

+---+ +---+ +---+ +---+ +---+ +---+
|SM| |10| |ST| |20| |20| |FF|
+---+ +---+ +---+ +---+ +---+ +---+

+---+ +---+ +---+ +---+ +---+ +---+
|ST| |1U| |FF| |SM| |FF| |ST|
+---+ +---+ +---+ +---+ +---+ +---+

```

Pattern Two

```

-----
+---+ +---+ +---+ +---+ +---+ +---+
|SM| |FF| |20| |SM| |10| |ST|
+---+ +---+ +---+ +---+ +---+ +---+

+---+ +---+ +---+ +---+ +---+ +---+
|FF| |1U| |SM| |10| |1U| |20|
+---+ +---+ +---+ +---+ +---+ +---+

+---+ +---+ +---+ +---+ +---+ +---+
|ST| |FF| |ST| |SM| |FF| |ST|
+---+ +---+ +---+ +---+ +---+ +---+

```

Pattern Three

-----  
+--+ +--+ +--+ +--+ +--+ +--+  
|FF| |ST| |1U| |FF| |1U| |SM|  
+--+ +--+ +--+ +--+ +--+ +--+  
  
+--+ +--+ +--+ +--+ +--+ +--+  
|10| |SM| |FF| |ST| |SM| |10|  
+--+ +--+ +--+ +--+ +--+ +--+  
  
+--+ +--+ +--+ +--+ +--+ +--+  
|ST| |20| |20| |SM| |FF| |ST|  
+--+ +--+ +--+ +--+ +--+ +--+

Pattern Four

-----  
+--+ +--+ +--+ +--+ +--+ +--+  
|SM| |FF| |1U| |FF| |ST| |ST|  
+--+ +--+ +--+ +--+ +--+ +--+  
  
+--+ +--+ +--+ +--+ +--+ +--+  
|20| |ST| |SM| |10| |1U| |FF|  
+--+ +--+ +--+ +--+ +--+ +--+  
  
+--+ +--+ +--+ +--+ +--+ +--+  
|20| |SM| |10| |SM| |FF| |ST|  
+--+ +--+ +--+ +--+ +--+ +--+

Pattern Five

-----  
+--+ +--+ +--+ +--+ +--+ +--+  
|FF| |ST| |1U| |FF| |20| |SM|  
+--+ +--+ +--+ +--+ +--+ +--+  
  
+--+ +--+ +--+ +--+ +--+ +--+  
|10| |SM| |20| |1U| |SM| |10|  
+--+ +--+ +--+ +--+ +--+ +--+  
  
+--+ +--+ +--+ +--+ +--+ +--+  
|ST| |FF| |ST| |SM| |FF| |ST|  
+--+ +--+ +--+ +--+ +--+ +--+

Pattern Six

-----  
+--+ +--+ +--+ +--+ +--+ +--+  
|FF| |10| |1U| |FF| |1U| |SM|  
+--+ +--+ +--+ +--+ +--+ +--+  
  
+--+ +--+ +--+ +--+ +--+ +--+  
|ST| |SM| |20| |ST| |SM| |10|  
+--+ +--+ +--+ +--+ +--+ +--+  
  
+--+ +--+ +--+ +--+ +--+ +--+  
|ST| |FF| |20| |SM| |FF| |ST|  
+--+ +--+ +--+ +--+ +--+ +--+

Pattern Seven

```

-----
+--+ +--+ +--+ +--+ +--+ +--+
|SM| |FF| |20| |FF| |10| |ST|
+--+ +--+ +--+ +--+ +--+ +--+

+--+ +--+ +--+ +--+ +--+ +--+
|20| |1U| |SM| |10| |1U| |FF|
+--+ +--+ +--+ +--+ +--+ +--+

+--+ +--+ +--+ +--+ +--+ +--+
|ST| |SM| |ST| |SM| |FF| |ST|
+--+ +--+ +--+ +--+ +--+ +--+

```

Pattern Eight

```

-----
+--+ +--+ +--+ +--+ +--+ +--+
|FF| |20| |SM| |ST| |1U| |FF|
+--+ +--+ +--+ +--+ +--+ +--+

+--+ +--+ +--+ +--+ +--+ +--+
|1U| |FF| |10| |SM| |20| |ST|
+--+ +--+ +--+ +--+ +--+ +--+

+--+ +--+ +--+ +--+ +--+ +--+
|SM| |10| |ST| |SM| |FF| |ST|
+--+ +--+ +--+ +--+ +--+ +--+

```

Ok, to figure out which pattern you have, flip over the card fifth on the right on the highest row.

You have Pattern: One, if it is a Fire Flower.  
 Four, if it is a Starman.  
 Five, if it is 20 coins.

If you got 10 coins, flip over the very left-end card on the middle row.

You have Pattern: Two, if it is a Fire Flower.  
 Seven: if it is 20 coins.

OR

If you got a 1-Up, flip over the very left-end card on the middle row.

You have Pattern: Three, if it is 10 coins.  
 Six, if it is a Starman.  
 Eight, if it is a 1-Up.

Thanks to Brian Sulpher for letting me use this trick from his guide.

```

=====
                        8. Secrets
=====

```

Different Thanks from the King  
 -----

Complete an airship stage while wearing a Tanooki Suit, Frog Suit or Hammer

Brother suit. The King will give you a different thanking when you change him back to his normal state.

Lots of P-Wings

-----  
Finish the game and restart again to play all over, but with a full inventory of 28 P-Wings.

White Platform Trick

-----  
On white platforms, stand on top and duck. Stay ducking for a few seconds and Mario will fall through and land behind the scenery. You can use this trick to get the Warp Whistle in World 1-3. It also works in a few other levels.

=====

## 9. Guide Closing

=====

The closing stuff to my Super Mario Bros. 3 FAQ.

=====

### 9.01 - Credits

=====

My dad

For letting me come to his house and use his PC to update my FAQs ever since my own PC broke, and he's not bothered if I take lots of time or if I'm over constantly, so thanks very much, dad. (Thumbs up)

Steve "Psycho Penguin" McFadden

For being such a great friend on GameFAQs, and for help and support, and he's been my role model for FAQ-writing since I began, which was a while ago, and we're still praising each other's work, so I thank you deeply from the bottom of my heart, Steve. SHABBA!

Brian Sulpher

For encouragement during the making of this guide, and for letting me borrow the Card Game secret in the Secret Areas section.

Jeff "Atom Edge" Chan

For the lovely ASCII title.

The Mushroom Kingdom

For a whole load of info on enemies and items.

- <http://www.classicgaming.com/tmk/>

Jeff "CJayC" Veasey, the IGN staff, and other sites whom have posted this FAQ

For hosting all my work and allowing me to become a much more recognised author.

=====

### 9.02 - Legal Disclaimer

=====

This FAQ is copyright (c)2003-2006 and exclusive property of Ryan Harrison.

Everything contained in this file is my own info, unless it has been notified and credited as info from another source. This FAQ may ONLY appear on the following sites:

lup.com (<http://lup.com/>)  
GameFAQs (<http://www.gamefaqs.com/>)  
GameNotOver (<http://www.gamenotover.com/>)  
GamerHelp (<http://www.gamerhelp.com/>)  
HonestGamers (<http://www.honestgamers.com/>)  
IGN FAQs (<http://faqs.ign.com/>)  
Neoseeker (<https://www.neoseeker.com/>)  
Omega Gateway (<http://omegagateway.com/>)  
SuperCheats (<http://www.supercheats.com/>)

If you would like to post this guide on your site, feel free to do so, but only as long as you contact me first and I grant you permission. If any of my FAQs is marked as Version FINAL, I'm not going to let you post them up, as I don't have time to be registering with all the sites just to have my guides posted up. If you're going to be stupid and decide to post ANY of my FAQs, let alone this one, on your site without my permission, that is plagiarism, and it's illegal. So just don't do it. This FAQ may also NOT be sold for profit, published for profit or reproduced for profit. This document is protected by copyright law, and I will find out if you rip me off. However, if you would like to use some of my info for your own FAQ, then I have no problem with that, JUST SO LONG AS YOU ASK ME AND CREDIT ME. That is all.

=====  
9.03 - Contacting Me  
=====

If you wish to get in touch with me regarding my work, whether you have any questions, comments or suggestions for this or any other of my FAQs, my E-Mail address is [rharrisonfaqs\(at\)gmail.com](mailto:rharrisonfaqs@gmail.com). Please make sure that your questions have been answered within the file before you send them, because I do not have time to look and reply to E-Mails that already have the solutions posted up, and you will likely not get a reply. If the file is complete and has a version number FINAL then you should definitely re-check before you send an E-Mail to me, otherwise then I'd be glad to help you out.

If you do send something helpful to me, then I will include in a future update of the file and I will give credit to you for whatever you have submitted. Please have a sensible E-Mail topic like "FAQ Question" so that I do not mistake it for something else and delete it. Thanks for reading and take care.

<http://www.gamefaqs.com/features/recognition/22792.html>

This file is dedicated to the memory of the late Chris MacDonald, who died on May 17, 2004. Rest in Peace.

<http://www.gamefaqs.com/features/recognition/85.html>

-END OF FILE-