

Saga Frontier II Arts List

by Angga

Updated to v0.31 on Nov 4, 2000

```
    sss      GGG      ffffffff      tt
  sssss     GG GG     fffff  ffff      tt
 ssssss     GG      ff      tttttt
ssss  aa  GG GGG  aa  ff  fff  rrr  rr  ooo  n  nn  tt  oo  ee  rr  rrr  | |
ssss  aa a GG  GG  aa a  fffffff  rrr  o  o  nn  n  tt  ii  e  e  e  rrr  | |
  ssss  aaa GG  GG  aaa  ff      rr  ooo  n  n  tt  ii  eee  rr  _|_|_
  ssss  a  GG  GG  a  ff
  ssss      GGGGGG      ff
  sss      GG      ff
  sss      GG      ff
  ss      GG      ff
  s      GG
```

=====

SaGa Frontier II

Arts List

ver 0.31

by

ANDREAS ANGGA INDRAWAN

EMAIL:anggasquall@yahoo.com

Date : 16 August 2000

=====

The Arts below are from the Usa version or Europe ver?(i don't know because i use a pirate copy and it displays published by square europe????).I will only display the single Art from every weapon and magic as far as i found on this game. This FAQ should not be use for Commercial purposes. This FAQ may be distributed electronically freely, but don't change anything on it.And please let me know if you want to put this FAQ on your homepage.This FAQ is made and owned by me.

Update History

ver 0.1 First release with the Weapon Arts

ver 0.2 Some Correction,lot of Changes ,Add Magic/Anima Arts ,Other Arts and Credit section.

ver 0.3 Add Other section about learning The Arts and Fix some Error

ver 0.4 Fix Error about Martial Arts Dragon Revolution (Sorry -_-)

Contents

I.Weapon Arts

- 1.Martial Arts
- 2.Sword Arts
- 3.Axe Arts
- 4.Staff Arts
- 5.Spear Arts
- 6.Bow Arts

II.Magic/Anima Arts

- 1.Tree Arts
- 2.Stone/Rock Arts
- 3.Fire/Flame Arts
- 4.Water Arts
- 5.Tone Arts
- 6.Beast Arts

III.Other Arts

- 1.Weapon Arts Without Command
- 2.Anima Weapon Arts
- 3.Hybrid Arts
- 4.Special Arts

IV.Other

- 1.About learning The Weapon Arts

V.Special Thanks/Credit

=====

I.Weapon Arts

=====

/ Martial Arts \
 \ _____ /

1.Karate Punch Atk Power: 9 Wp Cost : 2 Command : Ready - Punch	11.Somersault Atk Power: 54 Wp Cost : 5 Command : Charge - Kick - Kick
2.Backhand Atk Power: 15 Wp Cost : 3 Command : Feint - Punch	12.Triangle Kick Atk Power: 57 Wp Cost : 6 Command : Feint - Kick - Kick
3.Rotation Kick Atk Power: Wp Cost : 3 Command : Charge - Kick	13.Sumo Throw Atk Power: 60 Wp Cost : 8 Command : Punch - Grab - Kick Effect : Stun Effect
4.Bear Paw Atk Power: 24 Wp Cost : 4 Command : Charge - Grab	14.Kitchen Sink Atk Power: 62 Wp Cost : 7 Command : Charge - Feint - Kick
5.Brawl Atk Power: 27 Wp Cost : 4 Command : Punch - Kick - Punch	15.Rolling Thunder Atk Power: 64 Wp Cost : 9 Command : Focus - Punch - Punch - Punch
6.Crush Beat(Best vs Stone Enemies) Atk Power: 35 Wp Cost : 4 Command : Charge - Punch - Punch	16.Tumbler Atk Power: 72 Wp Cost : 9 Command : Feint - Grab - Charge - Grab Effect : Stun
7.Heart Breaker Atk Power: 38 Wp Cost : 5 Command : Focus - Grab - Punch Effect : Cripple	17.Cascade Rising Atk Power: 79 Wp Cost : 10 Command : Focus - Kick - Kick - Kick
8.Arm Hammer Atk Power: 45 Wp Cost : 5 Command : Charge - Charge - Punch	18.Kamikaze (Cost Lp to use) Atk Power: 90 Wp Cost : 10 Command : Charge - Charge - Charge - Grab
9.Kick Rush Atk Power: 49 Wp Cost : 5 Command : Kick - Kick - Kick	19.Eradication Atk Power: 99 Wp Cost : 10 Command : Punch - Punch - Kick - Kick
10.Corkscrew Atk Power: 51 Wp Cost : 6 Command : Charge - Focus - Punch	

/ Sword Arts \
 \ _____ /

|1.Double Slash |11.Slice & Dice

Atk Power: 21	Atk Power: 49
Wp Cost : 2	Wp Cost : 5
Command : Cleave - Cleave	Command : Slash - Backslash - Cleave

2.Cross Slash	12.Dragon Tail
Atk Power: 25	Atk Power: 50
Wp Cost : 3	Wp Cost : 5
Command : Slash - Backslash	Command : Feint - Slash - Backslash

3.Strike Slash	13.Head Cracker (Best Vs Bettle)
Atk Power: 27	Atk Power: 52
Wp Cost : 3	Wp Cost : 6
Command : Feint - Slash	Command : Ready - Charge - Slash
Effect : Stun	

4.Running Slash	14.Heaven & Hell
Atk Power: 33	Atk Power: 55
Wp Cost : 3	Wp Cost : 6
Command : Feint - Backslash	Command : Charge - Slash - Backslash
	Effect : Stun

5.Mist Double	15.Head Wind
Atk Power: 34	Atk Power: 59
Wp Cost : 3	Wp Cost : 7
Command : Feint - Cleave - Slash	Command : Feint - Cleave - Backslash

6.Smash	16.Bull Crush
Atk Power: 37	Atk Power: 63
Wp Cost : 4	Wp Cost : 8
Command : Charge - Cleave	Command : Charge - Charge - Cleave

7.Final Letter	17.No Momment (Unavoidable Attack)
Atk Power: 39	Atk Power: 66
Wp Cost : 6	Wp Cost : 8
Command : Backslash - Cleave -Backslash	Command : Ready - Ready - Ready - Slash
Effect : Deathblow	

8.Dead End	18.Blade Spray (Area Attack)
Atk Power: 42	Atk Power: 71
Wp Cost : 7	Wp Cost : 9
Command : Cleave - Backslash - Slash	Command : Ready - Charge - Charge - Backslash
Effect : Deathblow	

9.Double Stroke	19.Bear Crush
Atk Power: 44	Atk Power: 80
Wp Cost : 4	Wp Cost : 10
Command : Ready - Backslash - Backslash	Command : Charge - Charge - Charge - Cleave

10.Cross Break	20.Multi - Way
Atk Power: 46	Atk Power: 88
Wp Cost : 5	Wp Cost : 13
Command : Charge - Cleave - Cleave	Command : Slash - Backslash - Cleave - Slash

/ Axe Arts \
 \ /

1.Tomahawk	11.Mega Hit
Atk Power: 17	Atk Power: 60
Wp Cost : 2	Wp Cost : 6
Command : Charge - Throw	Command : Ready - Charge - Slash

2.Heel Crush	12.Wheel Grind
Atk Power: 19	Atk Power: 61

Wp Cost : 2	Wp Cost : 5
Command : Focus - Backslash	Command : Feint - Slash - Slash - Slash

3.Hyper Hammer	13.Flash Trinity
Atk Power: 24	Atk Power: 70
Wp Cost : 3	Wp Cost : 8
Command : Charge - Backslash	Command : Ready - Slash - Slash - Backslash

4.Wood Cutter(Best vs Plants)	14.Sky Rendezvous
Atk Power: 27	Atk Power: 73
Wp Cost : 4	Wp Cost : 9
Command : Charge - Charge - Slash	Command : Throw - Throw - Focus - Throw

5.Fake Out	15.Tornado Divide(Best vs Plants)
Atk Power: 34	Atk Power: 91
Wp Cost : 3	Wp Cost : 12
Command : Feint - Backslash - Slash	Command : Backslash - Backslash - Charge - Slash

6.Skull Crush(Best vs Skeletons)	
Atk Power: 40	
Wp Cost : 4	
Command : Focus - Charge - Slash	

7.Axel Turn	
Atk Power: 44	
Wp Cost : 5	
Command : Ready - Charge - Backslash	

8.Ogre Crossing	
Atk Power: 49	
Wp Cost : 4	
Command : Ready - Backslash - Backslash	

9.Sky Drive	
Atk Power: 53	
Wp Cost : 5	
Command : Charge - Feint - Throw	

10.Yo-Yo	
Atk Power: 55	
Wp Cost : 7	
Command : Focus -Charge - Throw - Throw	

/Staff Arts\

/

1.Roll Beat(Unavoidable Attack)	6.Gong Beat
Atk Power: 10	Atk Power: 42
Wp Cost : 2	Wp Cost : 6
Command : Swing - Swing	Command : Ready - Charge - Swing

2.Heart Beat	7.Painful Beat
Atk Power: 14	Atk Power: 45
Wp Cost : 3	Wp Cost : 5
Command : Focus - Beat	Command : Ready - Focus - Beat
Effect : Cripple	

3.Lobster Slayer(Best vs Shellfish)	8.Rock Crush(Best vs Stone enemies)
Atk Power: 28	Atk Power: 50
Wp Cost : 4	Wp Cost : 7
Command : Swing - Feint -Swing	Command : Charge - Beat - Beat - Beat

4.Bone Crush(Best vs Skeletons)	9.Turtle Killer(Unblockable by Shield)
Atk Power: 31	Atk Power: 61
Wp Cost : 4	Wp Cost : 10
Command : Focus - Charge - Beat	Command : Charge - Focus - Focus - Beat
-----	-----
5.Head Splitter	10.Time & Tide(Unavoidable - Deathblow)
Atk Power: 34	Atk Power: 77
Wp Cost : 4	Wp Cost : 14
Command : Focus - Focus - Beat	Command : Feint - Focus - Beat - Beat
-----	-----

/Spear Arts\
_____/

1.Swing And Stab	11.Beast Lightning
Atk Power: 18	Atk Power: 69
Wp Cost : 2	Wp Cost : 9
Command : Backslash - Thrust	Command : Ready - Focus - Backslash - Thrust
-----	-----

2.Double Thrust	12.Thousand Cross(Best vs Undead)
Atk Power: 22	Atk Power: 80
Wp Cost : 2	Wp Cost : 12
Command : Thrust - Thrust	Command : Thrust - Thrust - Thrust - Thrust
-----	-----

3.Lawnmower(Best vs Plants)	13.Fearless Triple
Atk Power: 27	Atk Power: 88
Wp Cost : 4	Wp Cost : 14
Command : Backslash - Backslash Thrust	Command : Feint - Backslash - Backslash -
Effect : Stun	
-----	-----

4.Skewer	14.Rush
Atk Power: 36	Atk Power: 32
Wp Cost : 4	Wp Cost : 3
Command : Charge - Charge - Thrust	Command : Charge - Thrust
-----	-----

5.Wave Thrust	
Atk Power: 43	
Wp Cost : 5	
Command : Backslash - Thrust - Thrust	

```

|-----|
|6.Brain Shaker                               |
|  Atk Power: 51                             |
|  Wp Cost   : 4                             |
|  Command   : Focus - Feint - Thrust        |
|-----|
|7.Aiming(Unavoidable)                       |
|  Atk Power: 55                             |
|  Wp Cost   : 5                             |
|  Command   : Focus - Focus - Thrust        |
|-----|
|8.Squash                                     |
|  Atk Power: 57                             |
|  Wp Cost   : 6                             |
|  Command   : Feint - Backslash - Thrust    |
|-----|
|9.Shining Arm(Unavoidable)                  |
|  Atk Power: 63                             |
|  Wp Cost   : 8                             |
|  Command   : Charge - Feint - Thrust       |
|-----|
|10.Heavenly Strike                          |
|  Atk Power: 65                             |
|  Wp Cost   : 10                            |
|  Command   : Backslash - Backslash - Thrust - Thrust |
|-----|

```

 /Bow Arts\

<pre> 1.Aim Shot Atk Power: 18 Wp Cost : 3 Command : Focus - Shoot </pre>	<pre> 6.Thousand Needle Atk Power: 52 Wp Cost : 6 Command : Quickshot - Quickshot - Shoot </pre>
<pre> 2.Shadow Bind Atk Power: 0 Wp Cost : 3 Command : Feint - Focus - Shoot Effect : Cripple </pre>	<pre> 7.Rapid Fire Atk Power: 55 Wp Cost : 7 Command : Charge - Quickshot x3 </pre>
<pre> 3.Mind Break Atk Power: 36 Wp Cost : 5 Command : Focus - Feint - Quickshot </pre>	<pre> 8.Hi Speed Arrow Atk Power: 64 Wp Cost : 7 Command : Charge - Focus - Focus - Quickshot </pre>
<pre> 4.Sidewinder(best vs frogs) Atk Power: 44 Wp Cost : 4 Command : Focus - Focus - Shoot </pre>	<pre> 9.Crystal Prism Atk Power: 84 Wp Cost : 9 Command : Quickshot - Shoot - Quickshot - Shoot Effect : Deathblow </pre>
<pre> 5.Shadow Slayer Atk Power: 49 Wp Cost : 6 Command : Shoot - Focus - Quickshot Effect : Deathblow </pre>	

=====

II.Magic/Anima Arts

=====

/Tree Arts\
 _____/

1.Needle Shot	4.Wood Stock
Atk Power: 36	Atk Power: 32
Jp cost : 4	Jp cost : 5
Command : Tree - Stone	Command : Tree - Beast

2.Bush Fire	5.Sleep
Atk Power: 28	Atk Power: -
Jp cost : 6	Jp Cost : 5
Command : Tree - Flame	Command : Tree - Tree - Flame

3.Life Water	6.Song of Earth
Atk Power: -	Atk Power: -
Jp Cost : 5	Jp Cost : 8
Command : Tree - Water	Command : Tree - Stone

/Stone/Rock Arts\
 _____/

1.Delta Petra(Area Attack)	4.Guard Beast
Atk Power: 50	Atk Power : -
Jp cost : 6	Jp Cost : 9
Command : Stone - Tree	Command : Stone - Stone - Beast
Effect : Petrify	

2.Magmaplosion(Area Attack)	5.Stone Armor
Atk Power: 38	Atk Power : -
Jp Cost : 5	Jp Cost : 4
Command : Stone - Flame	Command : Stone - Stone - Stone
	Effect : Raises Armor Strength

3.Water Hammer	
Atk Power:	
Jp Cost :	
Command : Stone - Water	
Effect : Psyche attack	

/Fire/Flame Arts\
 _____/

1.Recovery Breath(Removes Status)	4.Incineration(Combo spell)
Atk Power: -	Atk Power: 75
Jp Cost : 4	Jp Cost : 10
Command : Flame - Tree	Command :Flame - Flame - Tree - Stone
	Effect :Deathblow

2.Flame Naga(Area Attack,Best vs Frog)	5.Soul Hymn (Strengthens entire Party)
Atk Power: 40	Atk Power: -
Jp Cost : 5	Jp Cost : 16
Command : Flame - Beast	Command : Flame - Beast -Tone

3.Firestorm(Attack All)	

```
| Atk Power: 66 |
| Jp Cost : 8 |
| Command : Flame - Tree |
|-----|
```

/Water Arts\
 \-----/

1.Sonic Poison(Attack All)	4.Permanence(Maintains Target current Status)
Atk Power: 44	Atk Power: -
Jp Cost : 5	Jp Cost : 8
Command : Water - Tone	Command : Water - Water - Stone - Tree
Effect : Poison	

2.Aqua Viper(Area Attack,Best vs Frog)	5.Heaven's Thunder
Atk Power: 18	Atk Power: 70
Jp Cost : 4	Jp Cost : 9
Command : Water - Beast	Command : Water - Water - Tone - Tree

3.Call Thunder	
Atk Power: 60	
Jp Cost : 7	
Command : Water - Water - Tone	

/Tone Arts\
 \-----/

1.Sonic Burner(Area Attack)	4.Stone Memory
Atk Power: 21	Atk Power: -
Jp Cost : 6	Jp Cost : 7
Command : Tone - Flame	Command :Tone - Tone - Stone
	Effect :Petrify

2.Spoil Wave(Lowers Enemy Psy Within Area)	5.Hymnal(Atk All,Best vs undead)
Atk Power: -	Atk Power: 60
Jp Cost : 3	Jp Cost : 11
Command : Tone - Water	Command : Tone - Tree - Beast

3.Sonic Sanctuary(Strengthens spell defense)	
Atk Power: -	
Jp Cost : 4	
Command : Tone - Stone	

/Beast Arts\
 \-----/

1.Mind Scape(Raises entire party's reflex)	4.Berserk(Raises Moral to cause berserk)
Atk Power: -	Atk Power: -
Jp Cost : 3	Jp Cost : 3
Command : Beast - Tree	Command : Beast - Beast - Beast

2.Howling Heaven(Atk All)	5.Regenerate(Gives regenerative ability)
Atk Power: 32	Atk Power: -
Jp Cost : 5	Jp Cost : 3
Command : Beast - Tone	Command : Beast - Beast

3.Reviva(Endows Ability to ressurect self)	
Atk Power: -	
Jp Cost : 9	

=====
 III. Other Arts
 =====

1.Weapon Arts Without Command

 /Martial Arts\

 |1.Ogre Run(Area attack)|
 | Atk Power: 32 |
Wp Cost : 4

|2.Dragon Revolution |
 | Atk Power: 85 |
Wp Cost : 10

 / Spear Arts \

 |1.Wide Swing(Area Attack)|
 | Atk Power : 47 |
Wp Cost : 5

 / Sword Arts \

 |1.After Vision(Atk ALL)|
 | Atk Power: 55 |
Wp Cost : 7

 / Bow Arts \

 |1.Random Shot(Attack all)|
 | Atk Power : 12 |
Wp Cost : 2

 / Staff Arts \

 |1.Grand Slam(Atk all,Unavoidable)|
 | Atk Power: 74 |
Wp Cost : 8

|2.Arrow Rain(Attack All) |
 | Atk Power : 32 |
Wp Cost : 4

2.Anima Weapon Arts

 / Tree \

 |1.Wood Punch |4.Wood Spear |
 | Atk Power: 20 | Atk Power: 20 |
 | Jp Cost : 1 | Jp Cost : 2 |
 |-----|

|2.Wood Sword |5.Wood Arrow |
 | Atk Power: 20 | Atk Power: 20 |
 | Jp Cost : 2 | Jp Cost : 2 |
 |-----|

|3.Wood Staff |
 | Atk Power: 20 |
Jp Cost : 2

 / Stone \

 |1.Stone Punch |4.Stone Staff |
 | Atk Power: 20 | Atk Power: 20 |
 | Jp Cost : 1 | Jp Cost : 2 |
 |-----|

|2.Stone Sword |5.Stone Spear |
 | Atk Power: 20 | Atk Power: 20 |
 | Jp Cost : 2 | Jp Cost : 2 |
 |-----|

|3.Stone Axe |
 | Atk Power: 20 |
Jp Cost : 2

 / Flame \

 |1.Flame Sword |3.Flame Spear |
 | Atk Power: 30 | Atk Power: 30 |
 | Jp Cost : 2 | Jp Cost : 2 |
 |-----|

|2.Flame Axe |4.Flame Arrow |
 | Atk Power: 30 | Atk Power: 30 |
 | Jp Cost : 2 | Jp Cost : 2 |
 |-----|

 / Tone \

 |1.Tone Sword |3.Tone Arrow |
 | Atk Power: 20 | Atk Power: 20 |
 | Jp Cost : 2 | Jp Cost : 2 |
 |-----|

|2.Tone Staff |
 | Atk Power: 20 |
Jp Cost : 2

3.Hybrid Arts

／ Sword \ \ ／

```
|1.Tornado Blade(Tree Hybrid Arts,Area Attack)|
|  Atk Power : 74                               |
|  JP Cost   : 7                               |
|-----|
|2.Gale BLade(Tree Hybrid Arts)                 |
|  Atk Power : 94                               |
|  Jp Cost   : 10                              |
|  Command   :Tree - Cleave - Cleave - Slash  |
|-----|
|3.Thunder Blade(Water Hybrid Arts)             |
|  Atk Power : 50                               |
|  Jp Cost   : 6                               |
|  Command   : Water - Backslash - Cleave     |
|-----|
```

／ Axe \ \ ／

```
|1.Fire Wheel(Flame Hybrid Arts)                |
|  Atk Power : 45                               |
|  Jp Cost   : 5                               |
|  Command   : Flame - Charge - Throw        |
|-----|
```

／ Staff \ \ ／

```
|1.Gale Strike(Tree Hybrid Arts)               |
|  Atk Power : 74                               |
|  Jp Cost   : 7                               |
|  Command   : Tree - Swing - Swing - Swing  |
|-----|
```

／ Spear \ \ ／

```
|1.Snake Blaster(Water Hybrid Arts,Best vs Frogs)|
|  Atk Power : 72                               |
|  Jp Cost   : 6                               |
|  Command   : Water - Charge - Thrust       |
|-----|
|2.Twin Dragon (Flame - Water Hybrid)          |
|  Atk Power : 90                               |
|  Jp Cost   : 9                               |
|  Command   : Flame - Water - Thrust - Thrust|
|-----|
|3.Jewel Strike (Stone - Water Hybrid)         |
|  Atk Power : 99                               |
|  Jp Cost   : 15                              |
|  Command   : Stone - Water - Backslash 2x  |
|-----|
```

／ Bow \ \ ／

1.Bird Hunter(Flame hybrid Arts)	4.Spark Shot(Flame Hybrid Arts)
Atk Power : 31	Atk Power : 51
Jp Cost : 2	Jp cost : 7
Command : Flame - Shoot	Command :Flame - Quickshot - Quickshot

2.Poison Arrow(Water Hybrid Arts)	5.Wind Breaker(Tree Hybrid Arts)
Atk Power : 25	Atk Power : 60
Jp Cost : 4	Jp Cost : 8
Command : Water - Shoot	Command : Tree - Charge - Charge - Shoot
Effect : Poison	

3.Death Shot(Tree-Flame Hybrid Arts)	6.Spectral Shot(Beast Hybrid Arts)
Atk Power : 42	Atk Power : 66
Jp Cost : 4	Jp Cost : 9
Command : Tree - Flame - Shoot	Command :Beast - Beast - Beast - Quickshot
Effect : Deathblow	

7.Fire Bird(Flame Hybrids Arts,Heals Caster Hp)	
Atk Power : 33	
Jp Cost : 9	
Command : Flame - Beast - Shoot	

4.Special Arts

1.Comet Fall	
Atk Power : 51	
Jp Cost : 8	
Source : Kris Knife/Kris Acalabeth(Jp)	

IV.Other

About learning The Weapon Arts

Well There are a lot of People who Ask me about How is the exact way to learn the Arts.In this section i will try to give some information about how to get the Arts From the Group Battle.But First, I must say that the Information below are taken from Saga Frontier 2 Ultimania with the help from David Su(boko-kun@neteze.com) (Thanks for the explanation man :D).Hope this information Can help you and please remember that it is not 100% possibilities to get the art with only a single try on the Group Battle by using the chart below because there are may be have other condition too (Maybe about the weapon affinity(+Sign),The Enemy(Stronger enemy,better possibility).etc) and ofcourse you need a lot of luck to get them on The battle :P .Second,i'm not test all of them so don't blame me if it doesn't work and please tell me if it's really work ^_^.Now i will give you the explanation about the Chart below.

Ex:

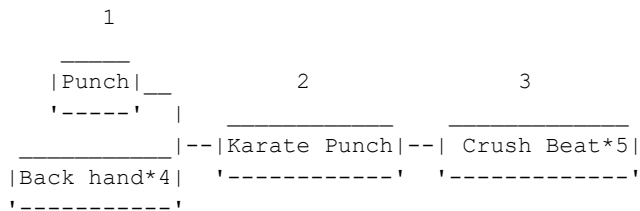

- 1.The Left side(Punch and Backhand) means you can use them(On the Group Battle) to get The Middle Side(Karate Punch)
- 2.The Middle Side(Karate punch) means There is a possibility that you can learn it by using the arts/move from the left side(Punch and Backhand)
- 3.The Right side(Crush Beat) means there is a possibility that you can learn it from the Middle side(karate Punch)
- 4.The *(On the left side) means it's really hard(very small possibility) to get the Middle side using that arts/move
- 5.The *(On the Right side)means It's really hard(Very small Possibility) to get the Art using the Middle side

Ok Let's start

1.Martial Arts

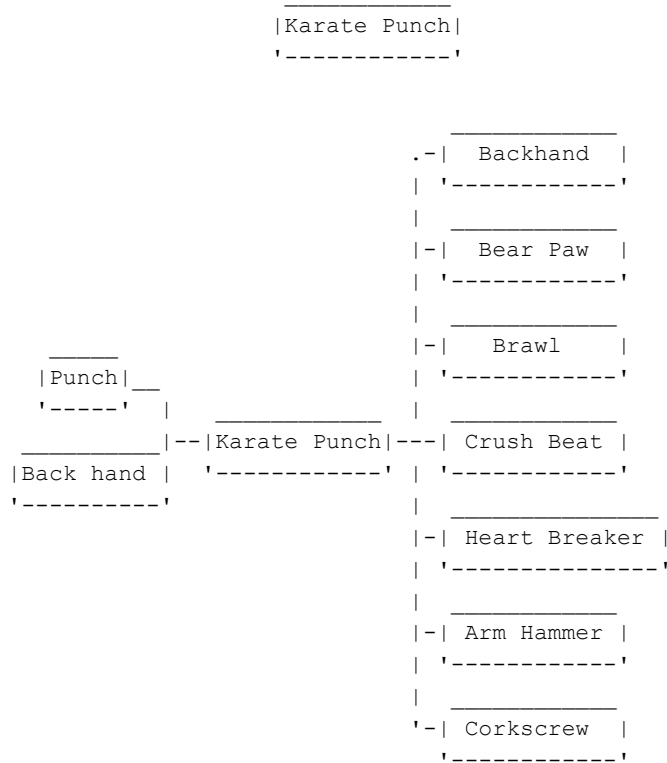

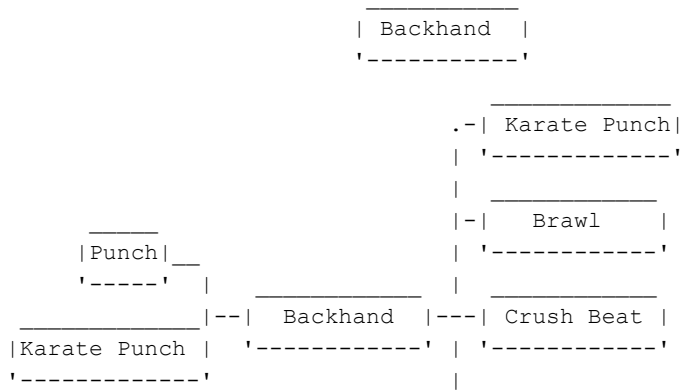

```
| - | Arm Hammer |
|   |-----|
|   |
|_  | Sumo Throw |
|   |-----|
```

```
| Rotation kick |
|-----|
```

```
      .-| Brawl |
      |-----|
      | -| Ogre Run |
      |-----|
      | -| Kick Rush |
      |-----|
      | -| Somersault | | |
|---|---|---|---|
|Punch|--|Rotation Kick|---|
|-----|-----|-----|
      | -| Triangle Kick |
      |-----|
      | -| Sumo Throw |
      |-----|
      | -| Kitchen Sink |
      |-----|
```

```
| Bear Paw |
|-----|
```

```
      .-| Brawl |
      |-----|
      | -| Ogre Run |
      |-----|
      | -| Crush Beat |
      |-----|
      | -| Heart Breaker |
      |-----|
      | -| Arm Hammer |
      |-----|
|Punch|_
|-----|
|Karate Punch|--| Bear Paw |---|
|-----|-----|-----|
```

```
| Brawl |
|-----|
```

```
| Punch | -
|-----|
|
|Karate Punch|--|
|-----|
      .-| Crush Beat |
```



```

      | Punch |-.
      '-----' |
    _____ |
|Karate Punch|---| Heart Breaker|---| Eradication*|
|-----| |-----| |-----|
    _____ |
|Bear Paw |-'
|-----|
  
```

```

    _____
|Arm Hammer|
|-----|
  
```

```

      | Punch |-.
      '-----' |
    _____ |
|Karate Punch|-'
|-----|
    _____ |
|Backhand|---| Arm Hammer |---| Ogre Run |
|-----| |-----| |-----|
    _____ |
|Ogre Run |-'
|-----|
    _____ |
|Bear Paw |-'
|-----|
    _____ |
|Crush Beat|-'
|-----|
    _____ |
|Heart Breaker|-'
|-----|
  
```

```

    _____
|Kick Rush|
|-----|
  
```

```

      | Punch |-.
      '-----' |
    _____ |
|Brawl |-'
|-----|
    _____ |
|Crush Beat|---| Kick Rush |---| Rolling thunder |
|-----| |-----| |-----|
    _____ |
|Rotation Kick |-'
|-----|
    _____ |
|Somersault|-'
|-----|
  
```

```

    _____
|Corkscrew |
|-----|
  
```

```

    | Punch |-.
    '-----' |
    |Karate Punch|-| .-| Rolling Thunder |
    '-----' | | '-----' |
    |Heart Breaker|---| Corkscrew |---| Eradication* |
    '-----' | | '-----' |
    |Arm Hammer |-'
    '-----'

```

```

    | Somersault |
    '-----'

```

```

    |Punch|_
    '-----' |
    |Rotation Kick|---| Somersault |---| Triangle Kick |
    '-----' | | '-----' |
    |Kick Rush|
    '-----' |
    |Cascade Rising|
    '-----'

```

```

    | Triangle Kick |
    '-----'

```

```

    | Punch |-.
    '-----' |
    |Rotation Kick|-| .-| Dragon Revolution |
    '-----' | | '-----' |
    |Ogre Run|---| Triangle Kick |---| Kamikaze* |
    '-----' | | '-----' |
    | Somersault|-
    '-----'

```

```

    | Sumo Throw |
    '-----'

```

```

    | Punch |-.
    '-----' |
    | Backhand|-
    '-----' |
    |Tumbler|
    '-----' |
    |Dragon Revolution|
    '-----'

```

Rotation Kick | Sumo Throw | Eradication*
Crush Beat

Kitchen Sink

Rotation Kick | Kitchen Sink | Dragon Revolution

Rolling Thunder

Punch
Brawl
Heart Breaker | Rolling Thunder
Crush Beat
Kick Rush
Corkscrew

Tumbler

Sumo Throw | Tumbler

Cascade Rising

Somersault | Cascade Rising

| Dragon Revolution |
'-----'

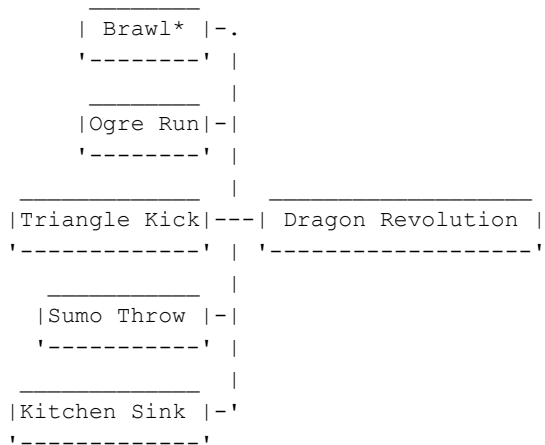

| Kamikaze |
'-----'

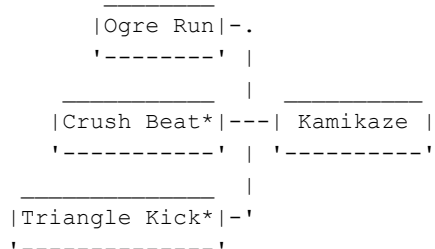

| Eradication |
'-----'

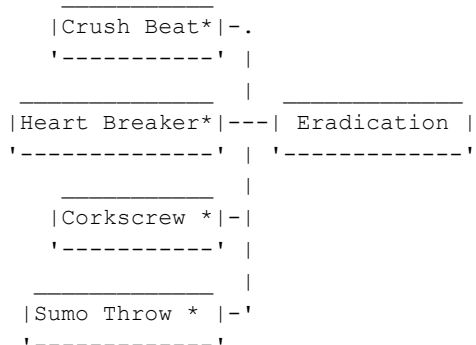

=====
2.Sword Arts

| Double Slash |
'-----'

.-| Cross Slash |
| '-----'

```

|
|-----|
|-| Mist Double|
| '-----'|
|
|-----|
|-| Final Letter|
| '-----'|
|
|-----|-----|-----|
|Slash |--|Double Slash|---| Cross Break|
|'-----'| '-----'| '-----'|
|
|-----|
|-| Slice And Dice|
| '-----'|
|
|-----|
|-| Dragon Tail|
| '-----'|
|
|-----|
|-| Heaven & Hell|
| '-----'|
|
|-----|
|-| Head Wind |
| '-----'|

```

```

|-----|
| Cross Slash |
| '-----'|

```

```

|-----|
.-| Dead End |
| '-----'|
|
|-----|
|-| Cross Break|
| '-----'|
|
|-----|-----|-----|
| Slash|_| Cross Slash|---| Slice and Dice |
|'-----'| '-----'| '-----'|
|-----|
|Double Slash |
|'-----'|
|
|-----|
|-| Heaven & Hell |
| '-----'|
|
|-----|
|_| Multy Way |
| '-----'|

```

```

|-----|
| Strike Slash |
| '-----'|

```

```

|-----|
.-|Running Slash|
| '-----'|
|
|-----|
|-| Mist Double|
| '-----'|
|
|-----|
|-| Dead End |
| '-----'|
|
|-----|-----|-----|
|Slash |--|Strike Slash|---| Dragon Tail|
|'-----'| '-----'| '-----'|
|
|-----|
|-| After Vision|
| '-----'|
|
|-----|
|-| No Momment |
| '-----'|

```

| Running Slash |
'-----'

```
      |-----|
      | Mist Double |
      |-----|
      |-----|
      | Double Stroke|
      |-----|
| Slash|_| | | |
|---|---|---|---|---|
|-----| |-----|
| Strike Slash | | Running Slash | | Head Wind |
|-----| |-----| |-----|
      |-----|
      |-----|
      | No Momment* |
      |-----|
      |-----|
      | Blade Spray* |
      |-----|
```

| Smash |
'-----'

```
      |-----|
      | Dead End |
      |-----|
      |-----|
      | Slice & Dice |
      |-----|
      |-----|
| Slash | | Smash | | Head Cracker |
|-----| |-----| |-----|
      |-----|
      |-----|
      | Bull Crush |
      |-----|
      |-----|
      | Bear Crush |
      |-----|
```

| Mist Double |
'-----'

```
      |-----|
      | Slash |-.
      |-----|
      |-----|
| Double Slash| |-----|
|-----| | Final Letter |
      |-----|
      |-----|
| Strike Slash| | Mist Double | | Slice & Dice |
|-----| |-----| |-----|
      |-----|
| Running Slash | |-----|
|-----| | Dragon Tail |
      |-----|
      |-----|
      | Heaven & hell |
      |-----|
      |-----|
      | Head Wind |
      |-----|
```

| _____
|-| After Vision|
| '-----'
| _____
|-| Blade Spray*|
| '-----'

| _____
| Final Letter|
| '-----'

| _____
| Slash* |-.
| '-----' |
| |
| _____ | _____
|Double Slash|---| Final Letter |
| '-----' | | '-----'
| |
| _____
|Mist Double|-'
| '-----'

| _____
| Dead End |
| '-----'

| _____
| Slash* |-.
| '-----' |
| |
| _____ | _____
| Cross Slash |---| Dead End |
| '-----' | | '-----'
| |
| _____
| Strike Slash | - |
| '-----' |
| |
| _____
| Smash | - '
| '-----'

| _____
| Double Stroke |
| '-----'

| _____ | _____
| Slash |-. |.-| Dragon Tail |
| '-----' | | '-----'
| |
| _____ | _____ | _____
|Running Slash|---|Double Stroke |---| Head Wind |
| '-----' | | '-----' | | '-----'

| _____
| Cross Break |
| '-----'

| _____
| Slash |-.
| '-----' |
| |
| _____ | _____
|Double Slash|-| |.-|Slice & Dice|
| '-----' | | '-----'

Cross Slash	Cross Break	Head Wind
Mist Double	Multy Way	

Slice & Dice

Slash		
Double Slash		
Cross slash	Slice & Dice	Multy Way *
Smash		
Mist Double		
Cross Break		

Dragon Tail

Slash		
Double Slash		Head Wind
Strike Slash	Dragon Tail	Blade Spray*
Mist Double		
Double Stroke		

Head Cracker

Slash		Heaven & Hell
Smash	Head Cracker	Bull Crush
		Bear Crush

| Heaven & Hell |
'-----'

| Slash |-.
'-----'
|
| Double Slash |-. | Bull crush |
'-----' | '-----'
|
| Cross Slash |---| Heaven & Hell |---| Bear Crush |
'-----' | '-----' | '-----'
|
| Mist Double |-.
'-----'
|
| Head Cracker |-'
'-----'

| Head Wind |
'-----'

| Slash |-.
'-----'
|
| Double Slash |-.
'-----'
|
| Running Slash |---| Head Wind |---| No Momment* |
'-----' | '-----' | '-----'
|
| Mist Double |-.
'-----'
|
| Double Stroke |-.
'-----'
|
| Cross Break |-.
'-----'
|
| Dragon Tail |-'
'-----'

| Bull Crush |
'-----'

| Slash |-.
'-----'
|
| Smash |-.
'-----'
|
| Head Cracker |---| Bull Crush |---| Bear Crush |
'-----' | '-----' | '-----'
|
| Heaven & hell |-'
'-----'

| After Vision |
'-----'

| Slash* |-.
'-----' |
| |
| Strike Slash |---| After Vision |
'-----' | '-----'
| |
| Mist Double |-'
'-----'

| No Momment |
'-----'

| Strike Slash |-.
'-----' |
| |
| Running Slash* |---| No Momment |
'-----' | '-----'
| |
| Head Wind* |-'
'-----'

| Blade Spray |
'-----'

| Strike Slash* |-.
'-----' |
| |
| Running Slash* |---| Blade Spray |
'-----' | '-----'
| |
| Head Wind* |-'
'-----'

| Bear Crush |
'-----'

| Slash* |-.
'-----' |
| |
| Smash |-|
'-----' |
| |
| Head Cracker |---| Bear Crush |
'-----' | '-----'
| |
| Heaven & hell |-|
'-----' |
| |
| Bull Crush |-'
'-----'

| Multy Way |
'-----'

| Cross slash |-.
'-----' |
| |

| Cross Break |---| Multy way |
'-----' | '-----'
| |

| Slice& Dice* |-'
'-----'

3.Axe Arts

| Tomahawk |
'-----'

.-| Sky Drive |
'-----'
| |

| Slash |--| Tomahawk |---| Yo-Yo |
'-----' | '-----'
| |

' -| Sky Rendezvous*|
'-----'

| Heel Crush|
'-----'

.-| Hyper Hammer|
'-----'
| |

|-| Wood Cutter|
'-----'
| |

| Slash |--| Heel Crush |---| Fake Out |
'-----' | '-----'
| |

|-| Axel Turn |
'-----'
| |

' -| Ogre Crossing |
'-----'

| Hyper Hammer|
'-----'

.-| Wood Cutter |
'-----'
| |

|-| Fake Out |
'-----'
| |

| Slash|---| Hyper Hammer|---|Skull Crush |
'-----' | '-----' | '-----'
| |

| |

| |

|Heel Crush |-'
'-----'

|-| Axel Turn |
'-----'
-
'-----'

-
'-----'

-
'-----'

| Wood Cutter |
'-----'

```
              .-| Fake Out |  
              | '-----'  
              |-----  
              |-| Skull Crush|  
              | '-----'  
              |-----  
    | Slash|-.  
    | '-----'|  
    |-----|  
|Heel Crush|---| Wood Cutter|---| Axel Turn |  
| '-----'| | '-----'| | '-----'|  
|-----| |-----| |-----|  
|Hyper Hammer |-'  
| '-----'|  
|-----|  
|-----|  
|-| Wheel grind|  
| '-----'  
|-----  
|-| Tornado Divide*|  
| '-----'
```

| Fake out |
'-----'

```
    | Slash |-.  
    | '-----'|  
    |-----|  
|Heel Crush|-.  
| '-----'|  
|-----|  
|Hyper Hammer|---| Fake Out |---| Yo-Yo |  
| '-----'| | '-----'| | '-----'|  
|-----| |-----| |-----|  
|Wood Cutter |-'  
| '-----'|  
|-----|  
|-----|  
|-| Flash Trinity|  
| '-----'
```

| Skull Crush |
'-----'

```
    | Slash|-.  
    | '-----'|  
    |-----|  
|Hyper Hammer|---| Skull Crush|---| Wheel Grind|  
| '-----'| | '-----'| | '-----'|  
|-----| |-----| |-----|
```

|Wood Cutter |-'
'-----'

'-| Flash Trinity |
'-----'

| Axel Turn |
'-----'

| Slash |-.
'-----' |
| Heel Crush |-' |
'-----' |
| Hyper Hammer |---| Axel turn |---| Wheel Grind |
'-----' | '-----' |
| Wood Cutter |-' | '-| Flash Trinity |
'-----' | '-----' |
| Fake Out |-'
'-----'

| Ogre Crossing |
'-----'

| Slash |-.
'-----' |
| Heel Crush |-' |
'-----' |
| Hyper Hammer |---| Ogre Crossing |---| Wheel Grind |
'-----' | '-----' |
| Wood Cutter |-' | '-| Flash Trinity |
'-----' | '-----' |
| Fake Out |-'
'-----' |
| Axel Turn |-'
'-----'

| Sky Drive |
'-----'

| Tomahawk |---| Sky Drive |---| Sky Rendezvous |
'-----' | '-----' |
| Tornado Divide |
'-----'

| Mega Hit |
'-----'

| Slash |-.
'-----' |

```
      |
      |Hyper Hammer|---| Mega Hit |---| Tornado Divide|
      |-----|   |-----|   |-----|
      |
      | Skull Crush |-'
      |-----|
```

```
      | Yo-Yo |
      |-----|
```

```
      | Tomahawk |-.
      |-----|
      |
      | Fake Out |---| Yo-Yo |
      |-----|   |-----|
```

```
      | Wheel Grind |
      |-----|
```

```
      | Slash |-.
      |-----|
      |
      | Skull Crush|-'
      |-----|
      |
      |Hyper Hammer|---| Wheel Grind |---| Flash Trinity|
      |-----|   |-----|   |-----|
      |
      | Wood Cutter |-'
      |-----|
      |
      |Ogre Crossing |-'
      |-----|
      |
      |Axel Turn |-'
      |-----|
```

```
      | Flash Trinity |
      |-----|
```

```
      | Slash |-.
      |-----|
      |
      | Fake Out |-'
      |-----|
      |
      |Skull Crush |---| Flash Trinity |
      |-----|   |-----|
      |
      | Axel Turn |-'
      |-----|
      |
      |Ogre Crossing |-'
      |-----|
      |
      |Wheel Grind |-'
      |-----|
```

| Sky Rendezvous |
'-----'

| Tomahawk * |-.
'-----'
|
| Sky Drive |---| Sky Rendezvous |
'-----' '-----'

| Tornado Divide |
'-----'

| Wood Cutter* |-.
'-----'
|
| Sky Drive* |---| Tornado Divide |
'-----' '-----'
|
| Mega Hit |-'
'-----'

4. Staff Arts

| Roll Beat |
'-----'

.-| Heart Beat |
| '-----'
|
|-| Lobster Slayer |
| '-----'
|
|-| Bone Crush |
| '-----'
|
| Beat |--| Roll Beat |---| Gong Beat |
'-----' '-----' '-----'
|
|-| Painful Beat |
| '-----'
|
|-| Rock Crush |
| '-----'
|
'-| Time & Tide* |
'-----'

| Heart Beat |
'-----'

.-| Lobster Slayer |
| '-----'
|
|-| Bone Crush |
| '-----'
|
| Beat |---| Heart Beat |---| Head Splitter |
'-----' '-----' '-----'
|
| Roll Beat |-' | Gong Beat |
'-----' '-----'

'-----'

|-| Painful Beat |

|-| Rock Crush |

|-| Time & Tide* |

| Lobster Slayer |

Beat -.			.- Bone Crush
-----			-----
-----		-----	-----
Roll Beat ---	Lobster Slayer	---	Rock Crush
-----	-----	-----	-----
-----			-----
Heart Beat -'			'- Turtle Killer
-----			-----

| Bone Crush |

Beat -.			.- Head Splitter
-----			-----
-----			-----
Roll Beat -			- Gong Beat
-----			-----
-----		-----	-----
Heart Beat ---	Bone Crush	---	Painful Beat
-----	-----	-----	-----
-----			-----
Lobster Slayer -'			- Rock Crush
-----			-----

			'- Turtle Killer

| Head Splitter |

Beat -.			.- Rock Crush
-----			-----
-----		-----	-----
Heart Beat ---	Head Splitter	---	Painful Beat
-----	-----	-----	-----
-----			-----
Bone Crush -'			'- Grand Slam
-----			-----

| Gong Beat |

| Beat | -.

```

|Roll Beat |-.| .-| Painful Beat | |
|-----| | |-----|
|-----| | |-----|
|Heart Beat|---|Gong Beat |---| Rock Crush |
|-----| | |-----|
|-----|
| Bone Crush|-'
|-----|

```

```

|-----|
| Painful Beat |
|-----|

```

```

| Beat |-.
|-----|
|-----|
| Roll Beat |-.
|-----|
|-----|
| Heart Beat |---| Painful Beat |---| Turtle Killer|
|-----| | |-----|
|-----| | |-----|
| Bone Crush |-.| -| Time & Tide * |
|-----| | |-----|
|-----|
| Head Splitter |-.
|-----|
|-----|
|Gong Beat |-'
|-----|

```

```

|-----|
| Rock Crush |
|-----|

```

```

| Beat |-.
|-----|
|-----|
|Roll Beat|-.
|-----|
|-----|
|Heart Beat|---| Rock Crush |---| Grand Slam |
|-----| | |-----|
|-----|
| Lobster Slayer |-.
|-----|
|-----|
| Bone Crush |-.
|-----|
|-----|
|Head Splitter|-.
|-----|
|-----|
|Gong Beat|-'
|-----|

```

```

|-----|
| Turtle Killer |
|-----|

```

```

| Beat |-.
|-----|
|-----|
|Lobster slayer*|---| Turtle Killer |

```

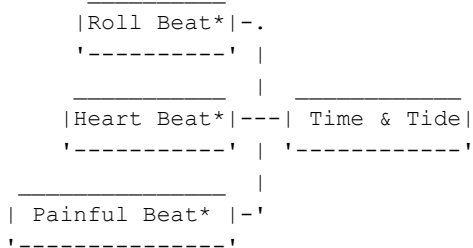
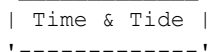
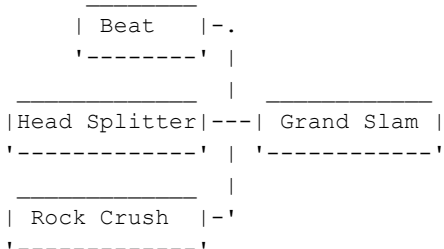
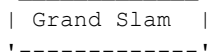
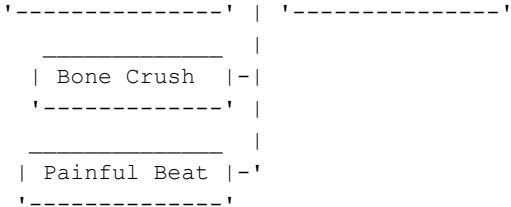

5.Spear Arts

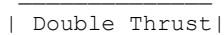
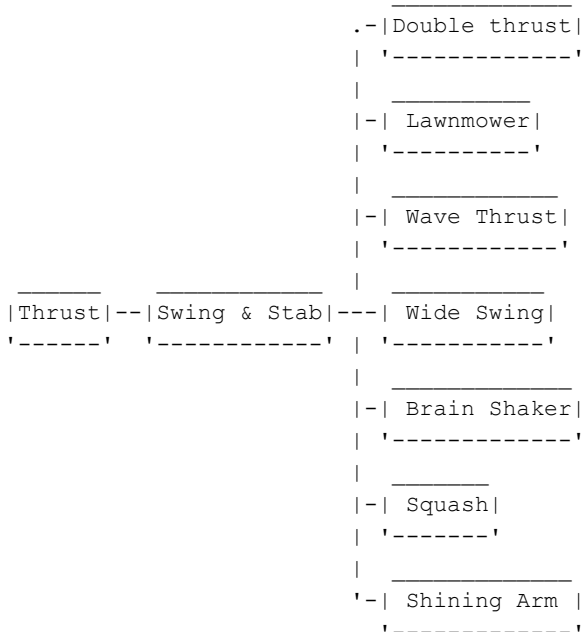
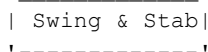

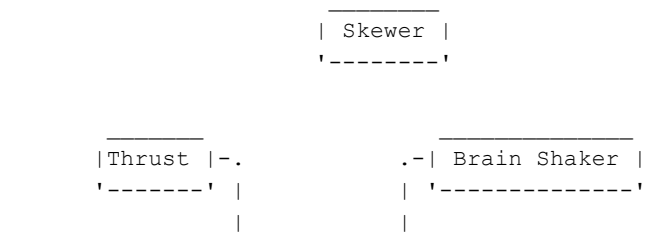
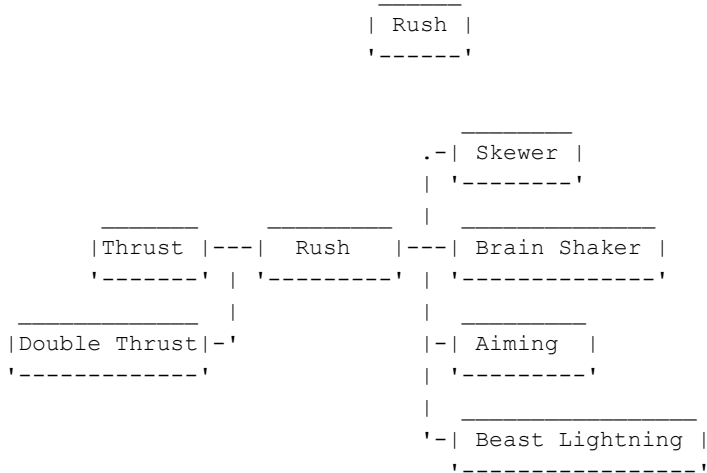
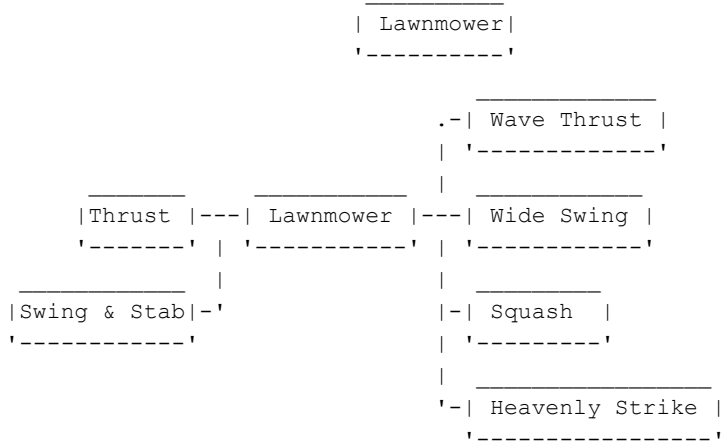
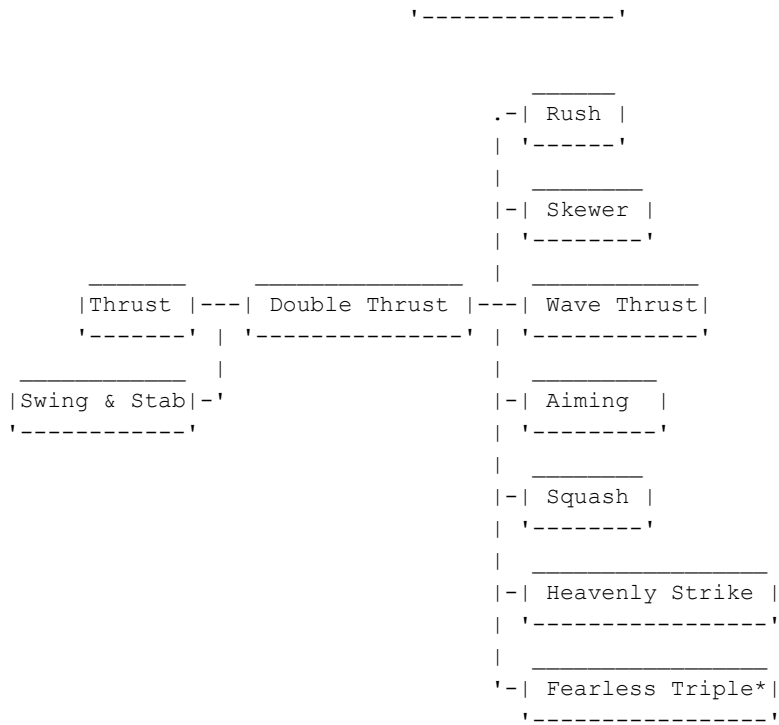

```

|Double Thrust |---| Skewer|---| Aiming |
|-----| |-----| |-----|
      |           |           |
      | Rush  |-'         '-| Shining Arm |
      |-----|         |-----|

```

```

| Wave Thrust |
|-----|

```

```

| Thrust |-.           .-| Wide Swing | | |
|-----| |           |-----|
      |           |           |
|Swing & Stab |-'         '-| Aiming |
|-----| |           |-----|
      |           |           |
|Double Thrust|---| Wave Thrust|---| Squash |
|-----| |-----| |-----|
      |           |           |
      |Lawnmower|-'         '-| Heavenly Strike |
      |-----|         |-----|
                        |-----|
                        '-| Fearless Triple *|
                        |-----|

```

```

| Wide Swing |
|-----|

```

```

| Thrust |-.           .-| Squash | | |
|-----| |           |-----|
      |           |           |
|Swing & Stab |-'         '-| Squash |
|-----| |           |-----|
      |           |           |
      |Lawnmower|---| Wide Swing |---| Heavenly Strike |
      |-----| |-----| |-----|
      |           |           |
      |Wave Thrust|-'
      |-----|

```

```

| Brain Shaker |
|-----|

```

```

| Thrust |-.           .-| Aiming | | |
|-----| |           |-----|
      |           |           |
|Swing & Stab |-'         '-| Squash |
|-----| |           |-----|
      |           |           |
      | Rush |---| Brain Shaker|---| Beast Lightning |
      |-----| |-----| |-----|
      |           |           |
      |Skewer|-'
      |-----|

```

```

| Aiming |
|-----|

```

```

| Thrust |-.
|-----|
      |

```

```

|Double Thrust|-|                .-| Shining Arm |
|-----| |                | '-----'
      |                |
      |-----| |                | | |
      | Rush |---| Aiming |---| Beast Lightning |
      |-----| |                |
      |-----| |                |
      |Skewer|-|                '-| Thousand Cross*|
      |-----| |                |-----'
      |                |
      |-----| |                |
      | Wave Thrust |-|                |
      |-----| |                |
      |                |
      |-----| |                |
      |Brain Shaker|-|                |
      |-----| |                |

```

```

      |-----|
      | Squash |
      |-----|

```

```

      |-----|
      | Thrust |-.
      |-----| | | |
      |-----| |                |
      |Swing & Stab |-|                .-| Heavenly Strike |
      |-----| |                | '-----'
      |                |
      |-----| |                |
      | Double Thrust |---| Squash |---| Fearless Triple*|
      |-----| |                |-----'
      |                |
      |-----| |                |
      |Lawnmower|-|                |
      |-----| |                |
      |                |
      |-----| |                |
      | Wave Thrust |-|                |
      |-----| |                |
      |                |
      |-----| |                |
      |Wide Swing |-.|                |
      |-----| |                |
      |                |
      |-----| |                |
      |Brain Shaker|-|                |
      |-----| |                |

```

```

      |-----|
      | Shining Arm |
      |-----|

```

```

      |-----|
      |Swing & Stab |-.|                .-| Beast Lightning |
      |-----| |                | '-----'
      |                |
      |-----| |                |
      | Skewer |---| Shining Arm |---| Thousand Cross* |
      |-----| |                |-----'
      |                |
      |-----| |                |
      |Aiming|-|                |
      |-----| |                |

```

```

      |-----|
      | Heavenly Strike |
      |-----|

```

```

      |-----|
      | Thrust |-.
      |-----| | |
      |-----| |                |
      |Double Thrust |-|                |
      |-----| |                |
      |                |
      |-----| |                |
      | Lawnmower |---| Heavenly Strike |---| Fearless Triple*|
      |-----| |                |-----'

```

Wave Thrust	-

Squash	-

| Wide Swing | - |
|-----|

Beast Lightning

| Thrust | - .

Rush	-	

Brain Shaker	---	Beast Lightning
-----		-----
Aiming	-	

| Shining Arm | - |
|-----|

Thousand Cross

| Aiming* | - .

Shining Arm	---	Thousand Cross
-----		-----

Fearless Triple

| Double Thrust* | - .

Wave Thrust*	---	Beast Lightning
-----		-----
Squash*	-	

| Heavenly Strike | - |
|-----|

5. Bow Arts

Aim Shot

.-| Shadow Bind |

```
      | - | Mind Break |
      | '-----' |
      | _____ |
      | - | Sidewinder |
      | '-----' |
      | _____ |
| Shoot | -- | Aim Shot | --- | Shadow Slayer |
| '-----' | | '-----' | | '-----' |
      | _____ |
      | - | Thousand Needle |
      | '-----' |
      | _____ |
      | - | Hi Speed Arrow |
      | '-----' |
```

```
      | _____ |
      | Random Shot |
      | '-----' |
```

```
      | _____ |      | _____ |      | _____ |
| Shoot | -- | Random Shot | --- | Arrow Rain |
| '-----' | | '-----' | | '-----' |
```

```
      | _____ |
      | Shadow Bind |
      | '-----' |
```

```
      | _____ |      | _____ | | |
| Shoot | -.          .- | Shadow Slayer |
| '-----' | | | '-----' |
      | _____ |      | _____ |
| Aim Shot | --- | Shadow Bind | --- | Hi Speed Arrow |
| '-----' | | '-----' | | '-----' |
```

```
      | _____ |
      | Arrow Rain |
      | '-----' |
```

```
      | _____ |
| Shoot | -.
| '-----' |
      | _____ |
| Random Shot | --- | Arrow Rain |
| '-----' | | '-----' |
```

```
      | _____ |
      | Mind Break |
      | '-----' |
```

```
      | _____ |      | _____ | | |
| Shoot | -.          .- | Sidewinder |
| '-----' | | | '-----' |
      | _____ |      | _____ |
| Aim Shot | --- | Mind Break | --- | Thousand Needle |
| '-----' | | '-----' | | '-----' |
```

```
      | _____ |
      | Sidewinder |
      | '-----' |
```

```
      | _____ |      | _____ | | |
| Shoot | -.          .- | Hi Speed Arrow |
| '-----' | | | '-----' |
      | _____ |      | _____ |
| Aim Shoot | --- | Sidewinder | --- | Crystal Prism |
| '-----' | | '-----' | | '-----' |
      | _____ |
```

|Mind Break|-'
'-----'

| Shadow Slayer |
'-----'

| Shoot |-. .-| Hi Speed Arrow |
'-----' | '-----'
| | |
| Aim Shoot |---| Shadow Slayer |---| Crystal Prism |
'-----' | '-----' | '-----'
| | |
| Shadow Bind|-'
'-----'

| Thousand Needle |
'-----'

| Shoot |-.
'-----' |
| | |
| Aim Shoot |---| Thousand Needle |---| Rapid Fire |
'-----' | '-----' | '-----'
| | |
| Mind Break |-'
'-----'

| Rapid Fire |
'-----'

| Thousand Needle |---| Rapid Fire |
'-----' | '-----'

| Hi Speed Arrow |
'-----'

| Shoot |-.
'-----' |
| | |
| Aim Shot |-|
'-----' |
| | |
| Shadow Bind |---| Hi Speed Arrow |
'-----' | '-----'
| | |
| Sidewinder|-'
'-----' |
| | |
| Shadow Slayer |-'
'-----'

| Crystal Prism |
'-----'

| Sidewinder |-.
'-----' |
| | |
| Shadow Slayer |---| Crystal Prism |
'-----' | '-----'

=====

IV.Credit/Special Thanks

- =====
- 1.Saga Frontier 2 Ultimania(Official Guide book),Edited by Studio Bentstuff,And Published by Digicube(www.digicube.co.jp) for providing a lot of Stuff that help me to complete this Arts List
 - 2.Guess Who for the Fire Wheel Arts
 - 3.Boen Boen for some addition and Correction
 - 4.NathanPs for some Correction
 - 5.Gamefaqs for posting this Faqs
 - 6.David Su (boko_kun@neteze.com)for a lot of suggestion and his explanation to me about learning the Arts from the Sf 2 ultimania
 - 7.MoiraRose@aol.com for tell me about some error on Martial Arts Dragon Revolution

If you have any suggestion ,Question or found any mistake here feel free to contact me

This document is copyright Angga and hosted by VGM with permission.